

(19) World Intellectual Property Organization  
International Bureau



(43) International Publication Date  
14 March 2002 (14.03.2002)

PCT

(10) International Publication Number  
WO 02/19924 A1

- (51) International Patent Classification<sup>7</sup>: A61B 17/08, F16B 15/00
- (72) Inventor: KANNER, Glenn; 106 Andrews Way, Plymouth, MA 02360 (US).
- (21) International Application Number: PCT/US00/24841
- (74) Agent: PFLEGER, Edmund, Paul; Hayes, Soloway, Hennessey, Grossman & Hage, P.C., 130 W. Cushing Street, Tucson, AZ 85701 (US).
- (22) International Filing Date: 11 September 2000 (11.09.2000)
- (81) Designated States (national): AE, AG, AL, AM, AT, AU, AZ, BA, BB, BG, BR, BY, BZ, CA, CH, CN, CR, CU, CZ, DE, DK, DM, DZ, EE, ES, FI, GB, GD, GE, GH, GM, HR, HU, ID, IL, IN, IS, JP, KE, KG, KP, KR, KZ, LC, LK, LR, LS, LT, LU, LV, MA, MD, MG, MK, MN, MW, MX, MZ, NO, NZ, PL, PT, RO, RU, SD, SE, SG, SI, SK, SL, TJ, TM, TR, TT, TZ, UA, UG, UZ, VN, YU, ZA, ZW.
- (25) Filing Language: English
- (26) Publication Language: English
- (30) Priority Data: 60/230,234 1 September 2000 (01.09.2000) US
- (84) Designated States (regional): ARIPO patent (GH, GM, KE, LS, MW, MZ, SD, SL, SZ, TZ, UG, ZW), Eurasian patent (AM, AZ, BY, KG, KZ, MD, RU, TJ, TM), European patent (AT, BE, CH, CY, DE, DK, ES, FI, FR, GB, GR, IE,

[Continued on next page]

(54) Title: WOUND SITE MANAGEMENT AND WOUND CLOSURE DEVICE

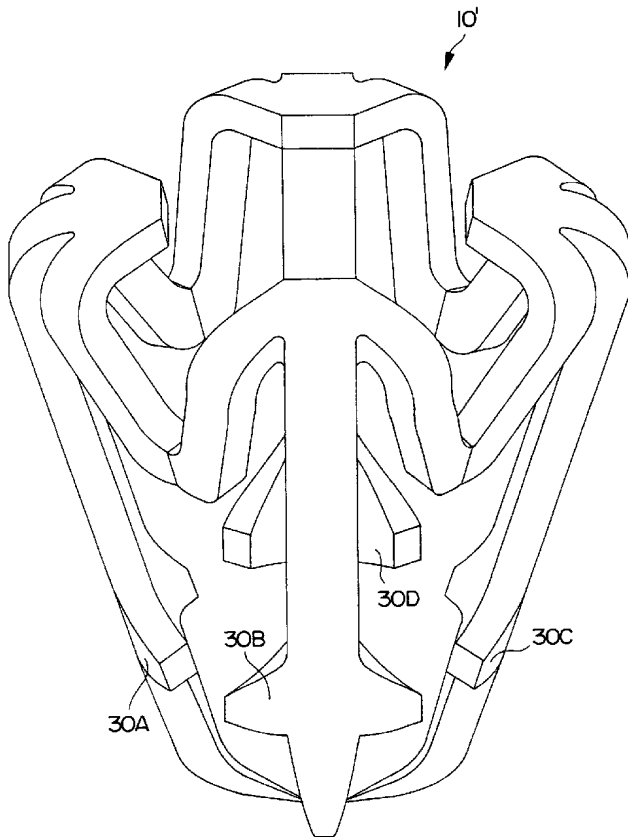

(57) Abstract: A staple (10) and stapler (102) and introducer (510) are disclosed for closing a wound and for wound site management. The staple is deformable, and includes a plurality of tissue-piercing prongs (12) which are expanded outwardly, inserted into tissue and collapsed inwardly to close the wound. The stapler includes a plurality of mechanisms to deform the staple into various positions. An introducer is provided that includes a plurality of spaced-apart wire guides (515) for securing and centering the wound opening during a medical procedure, and during closure of the wound.



WO 02/19924 A1



IT, LU, MC, NL, PT, SE), OAPI patent (BF, BJ, CF, CG, CI, CM, GA, GN, GW, ML, MR, NE, SN, TD, TG).

*For two-letter codes and other abbreviations, refer to the "Guidance Notes on Codes and Abbreviations" appearing at the beginning of each regular issue of the PCT Gazette.*

**Published:**

— *with international search report*

# WOUND SITE MANAGEMENT AND WOUND CLOSURE DEVICE

## BACKGROUND OF THE INVENTION

### 1. Field of the Invention

The present invention relates to a wound site management and wound closure device and method, for use during and after a medical procedure. More specifically, the present invention relates to a staple and stapling device for closing a puncture made in the wall of an artery or vein during a medical procedure. The puncture may be the result of a catheter-based intervention, although any puncture is contemplated, accidental or intentional. The present invention has particular utility for use in and around the femoral, radial, and brachial arteries after coronary/cardiac procedures. Other utilities include soft-tissue anchoring, tendon and artery joining, meniscal repair, thoracic lung closure, heart repair, endoscopic procedures, esophageal repair, laparoscopy, skin/epidermal wound closure and general tissue closure.

### 2. Description of Related Art

Catheters/catheterization procedures are well known, and typically involve insertions through the femoral artery for diagnosis or to treat cardiovascular and /or peripheral vascular diseases. After a diagnostic or interventional catheterization, the puncture formed by the catheter must be closed. The puncture opening in the artery typically ranges from 5F for a diagnostic procedure to 6-10F for an interventional procedure. Traditionally, intense pressure has been applied to the puncture site for at least 30-45 minutes after removal of the catheter. Other approaches include a thrombotic or collagen plug, and/or other suturing methodology for sealing the puncture. Patients who have had a femoral puncture are then required to remain at bed rest, essentially motionless and often with a heavy sandbag placed on their upper legs, for several hours to ensure that the bleeding has stopped. This traditional method of hemostasis following femoral artery access has many inadequacies. When a blockage is removed during a procedure, the patient quickly feels better and they often have more energy than they have had in years, but they must remain motionless for several hours. The weight of the sandbag on the femoral artery often causes the lower leg to tingle or go numb. The

1 recovery time from the medical procedure may be as little as ½ hour, but the recovery  
2 time from the wound can exceed 24 hours. This makes wound site management the  
3 longer critical care item. The longer the recovery time, the more expensive the procedure  
4 becomes, the greater the patient discomfort, and the greater the risk of complications.

5 Surgical stapling instruments have been proposed to resolve some of the  
6 aforementioned problems associated with vascular procedures. U.S Patent No. 5,709,335  
7 issued to Heck discloses a wholly distal surgical stapling instrument for stapling a tubular  
8 tissue structure to a luminal structure, such as a vascular lumen. This device can be used  
9 for anastomotic stapling of a tubular vessel having two untethered ends, and is especially  
10 useful for making the primary anastomotic connection of a bypass vein to a coronary  
11 artery or to the aorta. The device essentially includes a rod that is placed within the  
12 tubular vessel and an anvil that forces staples (associated with the rod) to bend outwardly  
13 against the vessel and a target (such as a coronary artery). Thus, this device requires that  
14 the stapler device be placed within the tubular vessel (e.g., vein or artery) for operation.  
15 While this device is useful when stapling a graft vein or the like, unfortunately, this  
16 device would be inappropriate when the entirety of the tubular tissue is not accessible,  
17 such as wound closure following a percutaneous transluminal diagnostic and  
18 interventional procedures and less invasive medical procedures.

19 Another example is found in U.S Patent No. 5,695,504 issued to Gifford, III et al.,  
20 discloses an end-to-side vascular anastomosis device to perform end-to-side anastomosis  
21 between a graft vessel and the wall of a target vessel. This device involves a procedure  
22 in which the end of a graft vessel is passed through an inner sleeve of the device until the  
23 end of the vessel extends from the distal end of the device. The distal end of the graft is  
24 then affixed to the wall of the target, using a staple and stapler which forces a staple into  
25 both tissues. Similar to the previous disclosures, this device is useful for the attachment  
26 of one tubular tissue onto another, however, is inadequate in sealing a puncture in an  
27 artery, vein or other tissue left by certain medical procedures.

28 Moreover, the prior art has failed to provide a device that permits a doctor or  
29 clinician to gain access to a puncture site and remain centered on that site throughout the

1 entire procedure, including closure of the puncture. Additionally, prior art devices do not  
2 permit a doctor or clinician to directly or indirectly view the wound site, for example  
3 through an endoscope, and thus success of the procedure at the site may be compromised.

#### 4 SUMMARY OF THE INVENTION

5 Accordingly, it is an overall object of the present invention to provide a device  
6 and method for wound site management and closure during and after medical procedures.

7 In one aspect, the present invention provides a tissue staple comprising a plurality  
8 of prongs connected to a plurality of tabs and arranged about a centerline axis. The  
9 prongs have a shoulder portion extending substantially orthogonal from the prong toward  
10 the centerline axis. Each prong has a tapered tissue-piercing portion on the distal end  
11 thereof.

12 Alternatively, the staple of the present invention comprises a plurality of prongs  
13 arranged about a centerline axis, each prong having a shoulder portion extending  
14 substantially orthogonal from the prong toward said centerline axis, and a plurality of  
15 web portions connecting each prong to one another, each prong having a tapered tissue-  
16 piercing portion on the distal end thereof.

17 In another aspect, the present invention provides a stapler that includes an  
18 elongated sleeve having an inside diameter, an elongated rod with a flared mandrel  
19 coupled to a distal end, the rod and mandrel sized to fit within the inside diameter of the  
20 tube, an actuator mechanism to move the rod relative to the sleeve, a staple adapted to fit  
21 between said mandrel and said sleeve, and, said actuator mechanism adapted to move  
22 said mandrel relative to said staple and said sleeve causing said staple to close on tissue  
23 located about a wound site.

24 Broader aspects of the stapler include a distal tip comprising a sleeve and a rod  
25 inserted into said sleeve, said rod comprising a flared distal tip; an actuator coupled to  
26 said sleeve and said rod, said actuator adapted to cause said sleeve to move relative to  
27 said rod; and a tissue staple comprising a plurality of tissue piercing prongs placed  
28 around said rod between said sleeve and said flared distal tip.

1           Wound closure procedures according to the present invention include a process  
2 for closing a wound comprising the steps of: inserting an introducer into a tissue wound,  
3 placing a sheath around the introducer and locating the sheath approximate to said  
4 wound, inserting the distal end of a stapler into said sheath to approach the tissue wound  
5 site, said stapler including a tissue staple on the distal end of said stapler, expanding a  
6 portion of the staple about said wound, and contracting at least a portion of said staple  
7 pulling together the tissue surrounding the wound.

8 Other wound closing methods include a process for closing a wound in an artery with a  
9 staple, comprising the steps of: inserting an introducer with a plurality of guide wires  
10 coupled thereto into an artery, guiding a stapler and staple to the wound site, expanding  
11 said staple to surround said wound site before entering said tissue, and closing said staple  
12 on said tissue to close said wound.

13           In yet another aspect, the present invention provides an introducer that includes a  
14 sheath having an inside diameter and a distal end, a dilator sized to fit within the inside  
15 diameter of the sheath, and a plurality of wire guides having first ends and second ends,  
16 the first ends coupled to the distal end of the sheath, wherein the sheath being  
17 approximated to a wound site and the wire guides placed into the wound site to hold said  
18 sheath approximately centered on said wound site.

19           In broader embodiment, the introducer of the present invention includes a tubular  
20 sheath, and at least one flexible wire guide affixed to the sheath, said wire guide placed  
21 into a wound site to hold said sheath approximately centered on said wound site.

22           In method form, the present invention also includes wound site stabilization  
23 methodology including the steps of: approximating an elongated sheath to a wound site;  
24           inserting one or more wire guides into the wound site; placing said wire guides  
25 approximate to tissue surrounding said wound site; and allowing opposing sides of said  
26 tissue surrounding said wound site to approximate one another.

27 Other procedural embodiments include a method for stabilizing a wound site, comprising  
28 the steps of: approximating an elongated sheath to a wound site; inserting one or more  
29 wire guides into the wound site; placing said wire guides approximate to tissue

1 surrounding said wound site; and centering said sheath about said wound site. It will  
2 be appreciated by those skilled in the art that although the following Detailed Description  
3 will proceed with reference being made to preferred embodiments, the present invention  
4 is not intended to be limited to these preferred embodiments. Other features and  
5 advantages of the present invention will become apparent as the following Detailed  
6 Description proceeds, and upon reference to the Drawings, wherein like numerals depict  
7 like parts, and wherein:

#### 8 BRIEF DESCRIPTION OF THE DRAWINGS

9 Figures 1-3 are isometric views of one embodiment of the staple of the present  
10 invention in formed, opened and deployed positions, respectively;

11 Figure 3A depicts an isometric view of alternative staple of the embodiment of  
12 Figures 1-3;

13 Figures 4-6 are isometric views of another embodiment of the staple of the  
14 present invention in formed, opened and deployed positions, respectively;

15 Figure 7 depicts one embodiment of the stapler of the present invention;

16 Figure 8 is an isometric view of the distal tip of the stapler of Figure 7 adapted to  
17 hold and deploy the staple of Figures 1-6;

18 Figures 9A-11B are isometric views of the cooperative movement of the distal tip  
19 of the stapler and the staple of the present invention;

20 Figures 12-15 are isometric views of an exemplary staple deployment mechanism  
21 of the stapler of the present invention;

22 Figures 16 and 17 are isometric views of another exemplary staple deployment  
23 mechanism of the stapler of the present invention; and

24 Figures 18-26 depict various views of procedural embodiments of the present  
25 invention, including Figure 20 depicting one embodiment of the introducer of the present  
26 invention.

#### 27 Detailed Description of the Invention

#### 28 Tissue Staple

1           In one aspect of the present invention, a staple is provided to close a tissue  
2 wound after a medical procedure. Although the preferred use of the staple of the present  
3 invention is to close an artery or vein following a diagnostic or interventional procedure,  
4 it should be recognized at the outset that the staple may be used for general tissue repair,  
5 not just limited to vascular repair. It will be appreciated throughout the following  
6 description that the staple of the present invention can be formed of any biocompatible  
7 and/or bioabsorbable materials, including, for example, Titanium (and Titanium alloys),  
8 stainless steel, polymeric materials (synthetic and/or natural), ceramic, etc. It will also be  
9 apparent from the following description that the staple of the present invention is  
10 preferably formed of a deformable material (such as those listed above) that undergoes  
11 plastic deformation (i.e., deformation with negligible elastic component.) As a general  
12 overview, the staple of the present invention undergoes two positions of deformation: a  
13 first position to extend the distal ends of the prongs of the staple outwardly to grab a  
14 greater amount of tissue (and also to grab tissue away from the wound locus), and a  
15 second position to move the prongs inwardly to close the wound.

16           Figures 1, 2 and 3 depict one embodiment of staple 10 of the present invention.  
17 Figure 1 is the staple in its formed position, Figure 2 is the staple just prior to  
18 deployment into tissue with the prongs extended outwardly, and Figure 3 is the staple  
19 closed around tissue. The staple 10 of this embodiment comprises a plurality of prongs  
20 12A-12D and a plurality of tabs 14A-14D, arranged about a centerline axis 100.  
21 Common portions, or shoulders 16A-16D are formed where the tabs meet the prongs.  
22 Each shoulder is common to both the prong and the tab and is generally defined by a  
23 relatively flat portion generally orthogonal to the centerline axis. Shoulders 16A-16D  
24 may be viewed as an extension of each prong, bent inwardly toward the centerline axis.  
25 Each of these features of the staple 10 of this embodiment is detailed below.  
26 In the formed position (Figure 1), prongs 12A-12D extend generally parallel to central  
27 axis 100, as shown. At the distal end of each prong, tapered points 18A-18D is formed to  
28 extend inwardly toward the centerline axis 100. At the proximal end, shoulders 16A-16D  
29 meet at prongs 12A-12D, respectively. Tabs 14A-14D are generally U-shaped, and are



1 formed between each prong. The proximal portions of each tab are joined at consecutive  
2 shoulders, as shown. Each proximal portion of the U (i.e., each “leg” of the U-shape tab)  
3 extends first generally outward from the shoulder, and second bends inwardly and  
4 distally toward centerline axis 100, connecting together nearest the centerline axis to  
5 form the U shape. The U-shape defines slots 20A-20D within each tab having a base  
6 positioned at the bottom thereof.

7 Referring specifically to Figure 2, the staple 10 is deformed so that prongs 12A-  
8 12D extend outwardly from the centerline axis, prior to deployment into tissue. It is  
9 advantageous to extend the prongs outwardly as shown so as to grasp a large portion of  
10 tissue, and so that insertion of the prongs into the tissue occurs at a locus away from the  
11 wound site, thereby providing a more consistent wound closure (by closing the wound  
12 with more of the surrounding tissue) and ensuring complete (or near complete) closure of  
13 the wound. To deform the staple into the position shown in Figure 2, a force  $F_1$  is  
14 applied to tabs 14A-14D, as shown in relief in Figure 2A. Force  $F_1$  is generally outward  
15 (from the centerline axis) and proximal to the top of the staple, as shown in relief in  
16 Figure 2A. This force causes the tabs to move outward from the centerline axis 100. The  
17 outward movement of the tabs causes the shoulder portions to pivot roughly about the  
18 juncture between the shoulder and the prong (i.e., at the outer portion of the shoulder),  
19 causing the inner portions of the shoulders to move inwardly toward the centerline axis  
20 and distally. Since the prongs are attached to the outer portion of the shoulders, the  
21 movement of the shoulders in this manner causes the prongs to move outwardly. Thus,  
22 the cross-sectional diameter of the staple gets larger at the distal end (with respect to the  
23 cross-sectional diameter of the formed staple of Figure 1). Note that the movement of the  
24 prongs is generally greater at the distal portions thereof than at the proximal portions  
25 thereof. In other words, movement of the prongs as shown in Figure 2 is pivoted from  
26 the shoulder, thus producing a staple with outwardly extending prongs. For  
27 completeness, it should be noted that a holding force may be applied downwardly (i.e.,  
28 substantially parallel to the centerline axis) against the base of the slots 20A-20D to hold  
29 the staple in place. Also, it is preferred that these forces are simultaneously applied to

1 each tab of the staple to produce uniform deformation of each prong of the staple. As  
2 mentioned above, it is preferable that the plastic deformation of the staple is semi-  
3 permanent, so that the staple does not tend to return to the shape depicted in Figure 1  
4 (i.e., non-elastic deformation). Deformation of the staple into this position will be  
5 described in greater detail below in reference to the preferred stapler device of the  
6 present invention.

7 Figure 3 depicts the staple 10 in a closed position. The closed position, as stated  
8 herein generally means that the prongs of the staple are moved inwardly toward each  
9 other. Although Figure 3 depicts the tapered tip portions of the prongs meeting generally  
10 in the vicinity of the centerline axis, however, it should be understood that the term  
11 "closed" or "deployed" as used in reference to the staple need not necessarily mean this  
12 precise configuration. It may be required (or desirable) for some procedures to move the  
13 prongs inwardly toward each other to a greater or lesser extent than as depicted in Figure  
14 3. To draw the staple into the closed position depicted in this Figure, a force  $F_3$  is  
15 applied to the inner surfaces 30A-30D of the shoulders. This force is generally  
16 orthogonal to the centerline axis, and the angle between each force approximates the  
17 angle between the inner surfaces 30A-30D (which, in the staple of this embodiment is  
18 approximately 90 degrees). This force causes the slots 20A-20D to spread apart and  
19 urges the shoulders outwardly. Movement in this manner also causes the shoulders to  
20 move outwardly and proximally. Proximal movement of the shoulders causes the prongs  
21 to move toward each other. Opposite to the movement of Figure 2, deformation shown  
22 in Figure 3 results in an expanded cross-sectional diameter of the proximal end of staple,  
23 and a diminished cross-sectional diameter of the distal end of the staple (with respect to  
24 the formed staple of Figure 1 and the deformed staple of Figure 2). Again, deformation  
25 of the staple 10 into this position will be described in greater detail below in reference to  
26 the preferred stapler device of the present invention.

27 For certain tissue application, it may be desirable that the staple of the present  
28 invention is deployed into tissue such that the prongs do not fully pierce through the  
29 tissue, but rather grasp and hold the tissue together. For example, for vascular closure

1 applications it may be desirable that the tissue piercing tapered ends not enter the  
2 bloodstream, but rather pierce into the tissue and stop short of piercing through the tissue  
3 wall. To that end, and referring to Figure 3A, the staple 10' of the present invention can  
4 be adapted with tissue stops 32A-32D. Preferably, tissue stops 32A-32D are located  
5 along the length of each prong, and positioned from the distal tip of the prong to permit  
6 the tapered ends to pierce tissue, but not pierce all the way through the tissue.  
7 Accordingly, the position of the stops 32A-32D along the length of the prongs is selected  
8 to facilitate tissue grabbing (but not complete tissue piercing) and can vary from  
9 application to application.

10       Figures 4-6 depict another embodiment of a staple 50 of the present invention.  
11 Figure 4 is the staple in it's formed position, Figure 5 is the staple just prior to  
12 deployment into tissue with the prongs extended outwardly, and Figure 6 is the staple  
13 closed around tissue. Similar to the first embodiment, the staple 50 of this embodiment  
14 comprises a plurality of prongs 52A-52D arranged about a centerline axis 100. A  
15 shoulder 56A-56D is provided and is generally defined by a relatively flat surface,  
16 generally orthogonal to centerline axis. Shoulders 56A-56D may be viewed as an  
17 extension of each prong, bent inwardly toward the centerline axis. In this embodiment,  
18 webs 54A-54D are connected to and between each prong, and are formed to extend  
19 inwardly from each prong toward the centerline axis, creating a U shape generally  
20 orthogonal to the centerline axis (as opposed to the previous embodiment in which the U-  
21 shaped tab is positioned generally parallel to the centerline axis). Each of the features of  
22 the staple 50 of this embodiment is detailed below.

23       In the formed position (Figure 4), prongs 52A-52D extend generally parallel to  
24 central axis 100, as shown. At the distal end of each prong, tapered points 58A-58D are  
25 formed to extend inwardly toward the centerline axis 100. At the proximal end,  
26 shoulders 56A-56D meet at prongs 52A-52D, respectively. Web portions (webs) 54A-  
27 54D are generally U-shaped, and are formed between each prong extending inwardly  
28 toward the centerline axis. As shown, webs connect the prongs at a position distal to the  
29 shoulders. The precise position of the webs is determined by the desired extent to which

1 the prongs are extended outwardly, and the extent to which the web curves inward  
2 toward the centerline axis. The space between the shoulders and the web portions  
3 defines a slot 60A-60D.

4 Referring specifically to Figure 5, the staple 50 is deformed so that prongs 52A-  
5 52D extend outwardly from the centerline axis, prior to deployment into tissue. As with  
6 the previous embodiment, it is advantageous to extend the prongs outwardly as shown so  
7 as to grasp a large portion of tissue, and so that insertion of the prongs into the tissue  
8 occurs at a locus away from the wound site, thereby providing a more consistent wound  
9 closure (by closing the wound with more of the surrounding tissue) and ensuring  
10 complete (or near complete) closure of the wound. To deform the staple into the position  
11 shown in Figure 5, a force  $F_1$  is applied to webs 54A-54D, as shown in relief in Figure  
12 5A. Force  $F_1$  is generally outward from the centerline axis and causes the webs to  
13 deform outwardly, i.e. straightening the bend of the web by moving the centermost point  
14 of the web outwardly. By deformation of the web portions in this manner, the prongs  
15 move outwardly. Thus, the cross-sectional diameter of the staple gets larger at the distal  
16 end (with respect to the cross-sectional diameter of the formed staple of Figure 4). Note  
17 that the movement of the prongs is generally greater at the distal portions thereof than at  
18 the proximal portions thereof, thus producing a staple with outwardly extending prongs.  
19 For completeness, it should be noted that a holding force may be applied downwardly  
20 (i.e., substantially parallel to the centerline axis) against the top of the webs in slots 60A-  
21 60D to hold the staple in place. Also, it is preferred that these forces are simultaneously  
22 applied to each web of the staple to produce uniform deformation of each prong of the  
23 staple. As mentioned above, it is preferable that the deformation of the staple is plastic,  
24 so that the staple does not tend to return to the shape depicted in Figure 4. Deformation  
25 of the staple into this position will be described in greater detail below in reference to the  
26 preferred stapler device of the present invention.

27 Figure 6 depicts the staple 50 in a closed or deployed position. The closed  
28 position, as stated herein generally means that the prongs of the staple are moved  
29 inwardly toward each other. To draw the staple into the closed position depicted in this

1 Figure, a force  $F_3$  is applied to the inner surfaces 62A-62D of the shoulders. This force is  
2 generally orthogonal to the centerline axis, and the angle between each force  
3 approximates the angle between the inner surfaces 62A-62D about the centerline axis  
4 (which, in the staple of this embodiment is approximately 90 degrees). This force urges  
5 the shoulders outwardly. Note that shoulders can only extend outwardly as far as the web  
6 portions will permit. Outward movement of the shoulders causes the prongs to move  
7 toward each other, since, there is a general pivot about the web portions. Opposite to the  
8 movement of Figure 5, deformation shown in Figure 6 results in an expanded cross-  
9 sectional diameter of the proximal end of staple, and a diminished cross-sectional  
10 diameter of the distal end of the staple (with respect to the formed staple of Figure 4 and  
11 the deformed staple of Figure 5). Again, deformation of the staple 50 into this position  
12 will be described in greater detail below in reference to the preferred stapler device of the  
13 present invention.

14 In either embodiment described above, it should be evident that although the  
15 Figures depict four each of the prongs, tabs and shoulders, this should be only be  
16 considered exemplary. It may be desirable to adapt the staple 10 or the staple 50 with  
17 more or fewer prongs, tabs and shoulders for a given application. Also, it is not  
18 necessary that each prong is the same length, or that each prong has the same overall  
19 dimensions. In alternative embodiments, the entire staple, or selected portions thereof  
20 can be alternatively fashioned from an elastic or shape memory (e.g., nitinol, and/or other  
21 elastic materials, including for example temperature dependant shape memory materials)  
22 material thereby permitting elastic deformation from the a static closed position to an  
23 expanded position and then elastically close about the wound. Also, the embodiment of  
24 Figures 4-6 can be adapted with a tissue stop positioned along the length of the prong, as  
25 shown in Figure 3A.

#### 26 Stapler Device

27 Another aspect of the present invention is a stapler device to deploy the staple 10  
28 of Figures 1-3, the staple 10' of Figure 3A, and the staple 50 of Figures 4-6. As a general  
29 overview, the stapler of the present invention includes a distal tip for holding and

1 deploying a staple, and an actuator mechanism to cause a staple, or at least the tissue  
2 piercing portions of a staple, to expand outwardly and then close about a wound. The  
3 stapler of the present invention facilitates one object of the present invention to ensure  
4 that the staple closes a greater amount of tissue as compared with conventional stapling  
5 mechanisms. The following description will detail various exemplary mechanisms to  
6 accomplish this goal, but it should be recognized that numerous alternatives will be  
7 readily apparent to those skilled in the art, and all such alternatives are to accomplish  
8 these objectives are deemed within the scope of the present invention.

9 Figure 7 depicts an isometric view of one embodiment of a stapling device 100 of  
10 the present invention. The device generally includes an actuation mechanism 104 and a  
11 distal tip 102. Figure 8 is a more detailed view of the distal tip 102 of the stapler device  
12 200. The distal tip preferably comprises an inner rod member 110 slidable within an  
13 outer sleeve 112. Rod 110 includes a flared or mandrel portion 114. Mandrel 114 also  
14 includes slots 118A-118D, which in use are aligned with fingers 116A-116D. Fingers  
15 116A-116D mate with slots 20A-20D and 60A-60D of the staple 10 and 50, respectively.  
16 Preferably, rod 110 is removable for staple attachment thereto, where a staple is  
17 positioned between the mandrel and the sleeve. The mandrel, as will be described below,  
18 is responsible for the forces generated on the staple.

19 Figures 9, 10A, 10B, 11A and 11B depict the working relationship between the  
20 staple 10' and/or 50 of the present invention and the mandrel 114/sleeve 112 of the  
21 stapler mechanism 200. In Figure 9A, the staple 10' is placed between the mandrel 114  
22 and sleeve 112. Slots 20A-20D of the staple engage fingers 116A-116D of the sleeve.  
23 The prongs 12A-12D of the staple are dimensioned so as to fit over the mandrel, and tabs  
24 14A-14D are dimensioned so as to fit over the rod 110, as shown. Similarly, for the  
25 staple 50 shown in Figure 9B the staple 50 engages the mandrel 114 and sleeve 112 (not  
26 shown). This is a static position, as no forces are applied to the staple to cause  
27 deformation. In Figure 10A, the staple 10' is urged into the first deformed position (of  
28 Figure 2) by the relative movement of the rod/mandrel and the sleeve. As shown, the  
29 mandrel is urged proximally. As the mandrel moves, the tabs of the staple meet the

1 narrowest part of the mandrel. Further movement forces the tabs to move outwardly,  
2 causing the prongs to likewise move outwardly (as described above with reference to  
3 Figure 2). Once the tabs clear the mandrel, outward movement of the tabs and prongs  
4 ceases. Similarly, in Figure 10B, the movement of the mandrel forces webs to extend  
5 outwardly causing the prongs to extend outwardly (as described above with reference to  
6 Figure 5). Once the webs clear the mandrel, outward movement of the prongs ceases.  
7 Figure 11A depicts final deployment of the staple into tissue. As the mandrel is drawn  
8 further proximally and once the tabs have cleared the mandrel, the shoulders (not shown)  
9 are spread outward, forcing the prongs to move together (toward the centerline axis) and  
10 closing tissue therebetween. Figure 11B depicts the same actuation, but for the staple 50  
11 of Figures 4-6.

12         Figures 12-15 depict an exemplary actuator mechanism 104, showing the relative  
13 motion of the sleeve 112 and the mandrel rod 110. The mechanism includes a cam 408  
14 movable in a linear motion along a slot 412. Movement of the cam can be manual or  
15 through an electronically controllable motor (not shown). The cam 408 has lobes 408A  
16 and 408C located on a first side of the cam 408 and a lobe 408B located on a second and  
17 opposing side of the cam 408. A first cam follower 418 is coupled to the mandrel rod  
18 110, and is selectably engagable with lobes 408A and 408C. A second cam follower 416  
19 is coupled to the sleeve 112, and is selectably engagable with lobe 408B. Figure 12  
20 depicts that neither cam follower is in contact with the lobes, and is indicative of an  
21 initial position of the mechanism.

22         Figure 13 depicts the mechanism 104 in a position to expand the staple between  
23 the mandrel 114 and the sleeve 112, as shown in Figure 9A. As cam 408 is moved (as  
24 indicated by the arrow), lobe 408A urges cam follower 418 along slot 426. The mandrel  
25 rod 110 is moved proximally, causing the prongs to extend outwardly (as shown in  
26 Figure 2 and 5) as a result of the force of the mandrel 114 on the tabs or the web portions.  
27 With further movement of the cam 408 (Figure 14), lobe 408B now urges cam follower  
28 416 to move distally, thereby moving the sleeve distally relative to the mandrel rod and  
29 causing further expansion of the prongs and causing the staple to move distally. Finally,

1 in Figure 15, the cam is urged yet further and cam follower 418 is urged by lobe 408C  
2 causing the mandrel and madre rod to extend further proximally. This relative  
3 movement between the cam rod and the sleeve causes the mandrel to apply a force to the  
4 shoulder portions of the staple, in turn causing inward movement of the prongs. Lobe  
5 408C causes closure of the prongs and decouples the staple from the mandrel. This is the  
6 fully deployed staple movement.

7 Figures 16 and 17 show an alternative cam mechanism. Similar to the previous  
8 example, cam 608 is urged in a direction indicated by the arrow to cause relative motion  
9 between the mandrel rod and the sleeve. Lobes 608A and 608B are located on opposite  
10 sides of cam 608. As the cam 608 is moved along slot 612, the lobe 608A urges a cam  
11 follower 618 in a linear motion along a slot 626. This urges the cam follower 618  
12 proximally. The cam follower 618 is coupled to a mandrel rod 604. This deforms staple  
13 10/50 in the second configuration (see Figure 2 or 5). As the cam 608 is urged further,  
14 the cam follower 618 moves distally to stay in contact with the lobe 608A. This urges  
15 mandrel rod 604 distally. The same movement of the cam 608 urges lobe 608B to urge  
16 cam follower 616 distally. The cam follower 616 is coupled to a sleeve 606. This urges  
17 sleeve 606 distally. The downward slope of lobe 608A is parallel with upward slope of  
18 lobe 608B so the mandrel rod 604 and the sleeve 606 move distally in unison and the  
19 staple is advanced into the tissue. The movement of the cam follower 618 down the  
20 slope of lobe 608A then ceases while the movement of cam follower 616 continues up  
21 the slope of lobe 608B and the staple 10/50 is deformed into the closed or deployed  
22 configuration (see Figure 3 or 6). Springs 614 and 650 can be provided to return cam  
23 followers 616 and 618, respectively, to an initial position. Of course an additional spring  
24 can be provided in slot 612 to move cam 608 back to an original position.

25 Alternatively, the actuation mechanism can include a rotating drum (not shown)  
26 to replace the cam 408 and 612. The drum may be adapted with lobes formed thereon,  
27 similar to lobes 408A-408C and 608A-608B, respectively. Other alternatives may  
28 include a rotating screw having a variable width in accordance with lobes 408A-408C or  
29 608A-608B to actuate the mandrel rod and/or sleeve. Of course, instead of the cam



1 mechanisms depicted in the Figures, direct linkage may be used to actuate the mandrel  
2 rod and/or sleeve.

### 3 Wound Site Management and Dilator

4 Figures 18-25A depict procedural embodiments of wound site management  
5 during and after a medical procedure, such as angioplasty. Figure 18 depicts a  
6 conventional tubular dilator 500 extending through the skin of a patient. Typically, the  
7 dilator 500 is left in the skin following a completed medical procedure. When the  
8 medical procedure has been completed, the wound site must be stabilized. Although the  
9 blood flow may not be completely stopped, the blood flow is reduced to a point where  
10 the coagulants in the blood can complete the wound closure. To start the stabilization  
11 process of the wound site, the doctor inserts a flexible guide wire 502 through an opening  
12 504 in the end of the dilator 500. Figure 19 shows the step of removing the introducer  
13 500 from the wound site after the guide wire 502 is properly inserted through the skin  
14 and into the vessel.

15 To facilitate efficient wound closure, another aspect of the present invention  
16 provides an introducer formed to center a closure device and/or elongate the wound site  
17 for more efficient and effective closure. Figure 20 depicts the introducer 510 of the  
18 present invention, and continues the process from Figures 18 and 19 where the introducer  
19 510 slides over the guide wire 502 through an opening in the introducer 510 and a portion  
20 of the introducer is placed into the vessel. Details of the introducer 510 are disclosed  
21 below.

22 Figure 20 depicts the introducer 510 inserted over the guide wire 502 (already in  
23 the artery) and inserted into the vessel. The introducer includes a hollow elongated guide  
24 sheath 512 and dilator 520. Referring to Figure 20A, the doctor urges the distal tip 516  
25 of the dilator 520 into and through the guide sheath 512 (over guide wire 502). A  
26 flexible distal end 516 of the dilator 520 is inserted into the wound, until a blood marker  
27 BM indicates that the dilator 520 is properly positioned in the artery. The blood marker  
28 BM located at a predetermined length along the dilator 520 allows blood to flow through  
29 a cavity 540 to alert the doctor that the dilator 520, and more specifically the flexible

1 distal tip 516, is properly inserted into a vessel. Most preferable, the distal tip 516 of the  
2 dilator includes a tapered portion 522 to facilitate easier ingress into the artery. An  
3 additional blood marking passageway (not shown) can be included on the distal end of  
4 sheath 512 as precautionary indicator of the depth of the sheath. Presence of blood in  
5 this additional passageway is indicative of the sheath being pressed too far and into the  
6 arterial wall or into the artery.

7 Preferably, the diameter of the distal end of the guide sheath 512 can expand if  
8 outward pressure is applied from the inside surface of the guide sheath 512. More  
9 preferably, slits or weakened tear seams (described below) are formed in the distal end of  
10 the guide sheath 512 to allow the diameter of the guide sheath to increase when pressure  
11 is applied.

12 A feature of the guide sheath of the present invention is the use of two or more  
13 wire guides to maintain the sheath centered on the wound site, to permit opposing sides  
14 of the wound to approximate, and to ensure that the closure device (e.g., stapler/staple,  
15 suturing device, cauterization, etc) remains centered about the wound so that wound  
16 closure is centered. Preferably, wire guides are formed on opposing sides of the guide  
17 sheath 512. The wire guides are delivered into the artery by the dilator 520, as shown in  
18 Figures 21 and 26. The wire guides 514 are preferably flexible, and removably coupled  
19 to the distal end 516 of the dilator 520 and deployed into the wound, as shown in figure  
20 26. The wire guides can be held in openings or slots (not shown) on the sides of the  
21 dilator. Once the dilator is properly inserted into the wound to a proper depth (as  
22 indicated by the BM passageway), the dilator is removed from the wound and the guide  
23 sheath. To remove the dilator 520 from the guide sheath 512, the doctor first holds the  
24 guide sheath 512 and advances the dilator 520 forward to release the wire guides, and  
25 then backward through the sheath to remove. This decouples the guide wires 514A and  
26 514B from the openings. After the guide rod has been inserted a predetermined  
27 distance, the doctor simply extracts the guide rod. This leaves the guide sheath 512  
28 centered on the wound with the guide wires 514A and 514B extending inside the wound.

1           As is understood to those skilled in the diagnostic and interventional arts, a  
2           puncture in an artery or vein has a general tendency to manifest a circumferential slit or  
3           an elongated opening, since the cell structure forming this tissue forms circumferentially  
4           (rather than longitudinal) to support radial contraction of the vessel. The wire guides  
5           514A and 514B of the present enable the wound to approximate the natural state of the  
6           wound, i.e., elongated circumferentially. Preferably, the sheath has a diameter  
7           approximately equal to the diameter of the opening or wound, and the wire guides 514A  
8           and 514B on the sides of the sheath approximate the dimension of the long axis of the  
9           wound in its natural, elongated state,, as best shown in Figure 23. Approximation in this  
10          sense may mean that the wire guides are less than or greater than (or equal to) this  
11          diameter. In effect, the wire guides in this position limit movement of the sheath along  
12          the long axis of the vessel, and since the wire guides span the elongated wound,  
13          movement along the short axis is likewise limited. This ensures that any device inserted  
14          through the sheath is approximately centered on the wound. Importantly, since the wound  
15          opening tends to assume the shape shown in Figure 23 even in the absence of the wire  
16          guides, the opposing tissue located along the short axis tends to approximate. The  
17          present invention takes advantage of this tendency for positioning and alignment of a  
18          sheath. If the position of the wire guides define a diameter larger than the diameter of the  
19          wound, the tissue along the short axis tends to approximate more (i.e., the tissue is  
20          stretched along the long axis). However, sufficient wound site management does not  
21          require that the wire guides stretch the wound. Rather, if the position of the wire guides  
22          are shorter than the wound length, the wire guides still serve to maintain the sheath  
23          generally centered at the wound. In both circumstances, the wire guides ensure that a  
24          staple deployment is centered, and that a significant amount of tissue is grasped by the  
25          staple for closure. Also, if the wound opening in the tissue is held taught by the  
26          introducer, there is less tendency for the tissue surrounding the opening to slip down into  
27          the vessel during staple deployment (which would reduce the effectiveness of the  
28          closure). Figure 23 also shows examples of locations S1, S2, S3, and S4 of where the  
29          prongs of the staple to be inserted will line-up relative to the wound opening WO. The

1 guide wires 514 are preferably disposed on opposing sides of the guide sheath 512, and  
2 more preferable, the guide wires are inserted into the wound opening transversally to the  
3 long axis of the artery or vein, so that the wound is pulled taught in a transverse direction.

4 Figure 22 shows the distal end of a stapler 104 with a staple 10/50 being inserted  
5 through the guide sheath 512 of the introducer 510. Figure 22A depicts a relief view of  
6 the introducer 510, and more clearly depicts the slits or weakened tear seams 700. When  
7 the distal end of the stapler 104 is properly inserted in the guide sheath 512, the staple  
8 can be deployed into the tissue. Figure 24 shows the first step of staple deployment, the  
9 process of which is described in detail above. Note that in Figure 24A, the extension of  
10 the staple prongs causes the weakened tear seam or slits to separate. This further causes  
11 the wire guides to expand against the long axis of the wound, thereby further  
12 approximating the tissue surrounding the opening. Figures 25 and 25A depict the staple  
13 fully deployed into tissue, the process of which is described above. The stapler can now  
14 be removed from the guide sheath 512. The guide sheath 512 can now be urged away  
15 from the wound opening WO and the guide wires 514A and 514B are extracted from the  
16 closed opening.

17 Although the present invention has been described in relation to particular  
18 embodiments thereof, many other variations and modifications and other uses will  
19 become apparent to those skilled in the art. It is preferred, therefore, that the present  
20 invention be limited not by the specific disclosure herein, but only by the appended  
21 claims.

CLAIMS

- 1
- 2 1. A tissue staple, comprising:
- 3 a plurality of prongs connected to a plurality of tabs and arranged about a
- 4 centerline axis; each said prong having a shoulder portion extending substantially
- 5 orthogonal from said prong toward said centerline axis, each said prong having a tapered
- 6 tissue-piercing portion on the distal end thereof.
- 7 2. A staple as claimed in claim 1, said tissue-piercing portion extending from said
- 8 prong inward toward said centerline axis.
- 9 3. A staple as claimed in claim 1, each said tab and prong connected together about
- 10 said centerline axis in an alternating fashion and axially from said centerline axis, each
- 11 said prong arranged substantially parallel to said centerline axis, and each said tab
- 12 extending distally and inwardly toward said centerline axis so that at least an inner
- 13 portion of each said tab is closer to said centerline axis than said prongs.
- 14 4. A staple as claimed in claim 3, said tab having a U-shape and connected to a
- 15 prong at each upper portion of said U-shape, said inner portion arranged to translate a
- 16 force thereon to each said prong, respectively, to move the distal ends of said prongs
- 17 outward from said centerline axis, pivoting approximately from an outer perimeter of
- 18 said shoulder portions.
- 19 5. A staple as claimed in claim 4, wherein said force causing said U-shape to spread
- 20 apart as the distal ends of said prongs move outward from said centerline axis.
- 21 6. A staple as claimed in claim 1, wherein said prongs, tabs and shoulders being
- 22 formed in a unitary fashion of a deformable biocompatible and/or bioabsorbable material.
- 23 7. A staple as claimed in claim 1, wherein the prongs, tabs and shoulders are
- 24 symmetrically located about said centerline axis, and said prongs and tabs are arranged in
- 25 an alternating fashion.
- 26 8. A staple as claimed in claim 1, wherein said shoulders arranged to translate a
- 27 force thereon to said prongs causing said distal ends to move toward said centerline axis.

- 1 9. A staple as claimed in claim 8, wherein said force being directed outwardly and  
2 generally orthogonally from said centerline axis.
- 3 10. A staple as claimed in claim 3, wherein said force being directed outwardly and  
4 generally orthogonally from said centerline axis.
- 5 11. A tissue staple, comprising:  
6 a plurality of prongs arranged about a centerline axis, each said prong having a  
7 shoulder portion extending substantially orthogonal from said prong toward said  
8 centerline axis, and a plurality of web portions connecting each said prong to one  
9 another, each said prong having a tapered tissue-piercing portion on the distal end  
10 thereof.
- 11 12. A tissue staple as claimed in claim 11, wherein said tissue-piercing portion  
12 extending from said prong inward toward said centerline axis.
- 13 13. A tissue staple as claimed in claim 11, wherein each said web portions and said  
14 prongs connected together about said centerline axis in an alternating fashion, each said  
15 prong arranged substantially parallel to said centerline axis, and each said web portion  
16 extending inwardly toward said centerline axis so that at least an inner portion of each  
17 said web portion is closer to said centerline axis than said prongs.
- 18 14. A tissue staple as claimed in claim 13, said inner portion arranged to deform and  
19 translate a force thereon to each said prong, respectively, to move the distal ends of said  
20 prongs outward from said centerline axis.
- 21 15. A tissue staple as claimed in claim 13, wherein said force causing web portion to  
22 deform outwardly from said centerline axis.
- 23 16. A staple as claimed in claim 11, wherein said prongs, web portions and shoulders  
24 being formed in a unitary fashion of a deformable biocompatible and/or bioabsorbable  
25 material.
- 26 17. A staple as claimed in claim 11, wherein the prongs, web portions and shoulders  
27 are symmetrically located about said centerline axis, and said prongs and web portions  
28 are arranged in an alternating fashion.

- 1 18. A staple as claimed in claim 11, wherein said shoulders arranged to translate a  
2 force thereon to said prongs causing said distal ends to move toward said centerline axis.
- 3 19. A staple as claimed in claim 14, wherein said force being directed outwardly and  
4 generally orthogonally from said centerline axis.
- 5 20. A staple as claimed in claim 18, wherein said force being directed outwardly and  
6 generally orthogonally from said centerline axis.
- 7 21. A staple as claimed in claim 8, where said movement of said distal ends grasping  
8 a portion of tissue so as to close an opening in said tissue without piercing completely  
9 through the walls of said tissue.
- 10 22. A staple as claimed in claim 1, wherein each said prong further comprising a  
11 tissue stop portion positioned at a selected point along the length of said prong to limit  
12 the penetration of said tissue-piercing portion into tissue.
- 13 23. A staple as claimed in claim 18, where said movement of said distal ends  
14 grasping a portion of tissue so as to close an opening in said tissue without piercing  
15 completely through the walls of said tissue.
- 16 24. A staple as claimed in claim 11, wherein each said prong further comprising a  
17 tissue stop portion positioned at a selected point along the length of said prong to limit  
18 the penetration of said tissue-piercing portion into tissue.
- 19 25. A staple as claimed in claim 1, wherein said prongs, tabs and shoulders being  
20 formed in a unitary fashion of an elastic biocompatible and/or bioabsorbable material.
- 21 26. A staple as claimed in claim 11, wherein said prongs, web portions and shoulders  
22 being formed in a unitary fashion of an elastic biocompatible and/or bioabsorbable  
23 material.
- 24 27. A tissue stapler, comprising  
25 an elongated sleeve having an inside diameter,  
26 an elongated rod with a flared mandrel couple to a distal end, the rod and mandrel  
27 sized to fit within the inside diameter of the tube,

- 1           an actuator mechanism to move the rod relative to the sleeve,  
2           a staple adapted to fit between said mandrel and said sleeve, and  
3           said actuator mechanism adapted to move said mandrel relative to said staple and  
4           said sleeve causing said staple to close on tissue located about a wound site.
- 5   28.    A tissue stapler as claimed in claim 27, said actuator mechanism comprising a  
6   cam for urging said sleeve to move relative to said mandrel.
- 7   29.    The stapling device of claim 28, further comprising a first cam follower coupled  
8   to said sleeve and a second cam follower coupled to said mandrel rod, said cam urging  
9   said first and second cam followers to move said sleeve relative to said mandrel.
- 10 30.    The stapling device of claim 27, wherein said mandrel causing at least a portion  
11 of said staple to expand before causing said staple to close on said tissue.
- 12 31.    The stapling device of claim 27, wherein said mandrel causes the staple prongs to  
13 contract inward thereby deploying said staple into said tissue.
- 14 32.    A stapler, comprising:  
15           a distal tip comprising a sleeve and a rod inserted into said sleeve, said rod  
16 comprising a flared distal tip;  
17           an actuator coupled to said sleeve and said rod, said actuator adapted to cause said  
18 sleeve to move relative to said rod; and  
19           a tissue staple comprising a plurality of tissue piercing prongs placed around said  
20 rod between said sleeve and said flared distal tip.
- 21 33.    A stapler as claimed in claim 32, wherein said movement of said sleeve relative to  
22 said rod causing said flared distal tip to expand said tissue piercing prongs away from  
23 said rod.
- 24 34.    A stapler as claimed in claim 32, wherein said movement of said sleeve relative to  
25 said rod causing said tissue piercing prongs to move together.
- 26 35.    A process for closing a wound, comprising the steps of:  
27           inserting an introducer into a tissue wound,  
28           placing a sheath around the introducer and locating the sheath approximate to said  
29 wound,



1           inserting the distal end of a stapler into said sheath to approach the tissue wound  
2 site, said stapler including a tissue staple on the distal end of said stapler,  
3           expanding a portion of the staple about said wound, and  
4           contracting at least a portion of said staple pulling the tissue surrounding the  
5 wound together.

6 36. A process for closing a wound in an artery with a staple, comprising the steps of:  
7           inserting an introducer with a plurality of guide wires coupled thereto into an  
8 artery,  
9           guiding a stapler and staple to the wound site,  
10          expanding said staple to surround said wound site before entering said tissue, and  
11 closing said staple on said tissue to close said wound.

12 37. An introducer, comprising:  
13          a sheath having an inside diameter and a distal end,  
14          a dilator sized to fit within the inside diameter of the sheath,  
15          a plurality of flexible wire guides having first ends and second ends, the first ends  
16 coupled to the distal end of the sheath, wherein the sheath being approximated to a  
17 wound site and the wire guides placed approximate to tissue surrounding the wound site  
18 to hold said sheath approximately centered on said wound site.

19 38. The introducer of claim 37, wherein the guide wires are coupled to the sheath in  
20 geometrical opposed positions.

21 39. The introducer of claim 37, wherein the wire guides urge the wound opening into  
22 an elongated configuration.

23 40. The introducer of claim 38, wherein said wound site is formed in an artery or vein  
24 and at least two of said guide wires placed at opposing ends of said wound and transverse  
25 to a long axis of said artery or vein.

- 1 41. The introducer of claim 37, further comprising a blood marker to signal when said  
2 dilator is inserted into the wound opening to a predetermined depth.
- 3 42. An introducer, comprising:  
4 a tubular sheath, and  
5 at least one flexible wire guide affixed to the sheath, said wire guide placed  
6 approximate to tissue surrounding a wound site to hold said sheath approximately  
7 centered on said wound site.
- 8 43. An introducer as claimed in claim 42, wherein said tubular sheath includes two  
9 flexible wire guides affixed at opposing sides of said tubular sheath.
- 10 44. An introducer as claimed in claim 43, wherein said wound site is formed in an  
11 artery or vein and said two of wire guides placed in said wound along a transverse axis  
12 relative to a long axis of said artery or vein.
- 13 45. An introducer of claim 42, further comprising a dilator inserted into said tubular  
14 sheath, at least a portion of said dilator being also inserted into said wound.
- 15 46. An introducer as claimed in claim 45, said dilator further comprising a fluid  
16 passageway to permit fluid to flow therethrough to indicate when said dilator is inserted  
17 into the wound opening to a predetermined depth.
- 18 47. An introducer as claimed in claim 45, wherein a portion of said wire guide being  
19 removably attached to said dilator.
- 20 48. An introducer as claimed in claim 42, wherein said sheath having an outside  
21 diameter approximately equal to the diameter of said wound.
- 22 49. A method for stabilizing a wound in an artery or vein comprising the steps of:  
23 approximating an elongated sheath to a wound site;  
24 placing one or more wire guides into the wound site;  
25 placing said wire guides approximate to tissue surrounding said wound site; and  
26 allowing opposing sides of said tissue surrounding said wound site to  
27 approximate one another.
- 28 50. A method for stabilizing a wound site, comprising the steps of:  
29 approximating an elongated sheath to a wound site;

- 1 inserting one or more wire guides into the wound site;
- 2 placing said wire guides approximate to tissue surrounding said wound site; and
- 3 centering said sheath about said wound site.

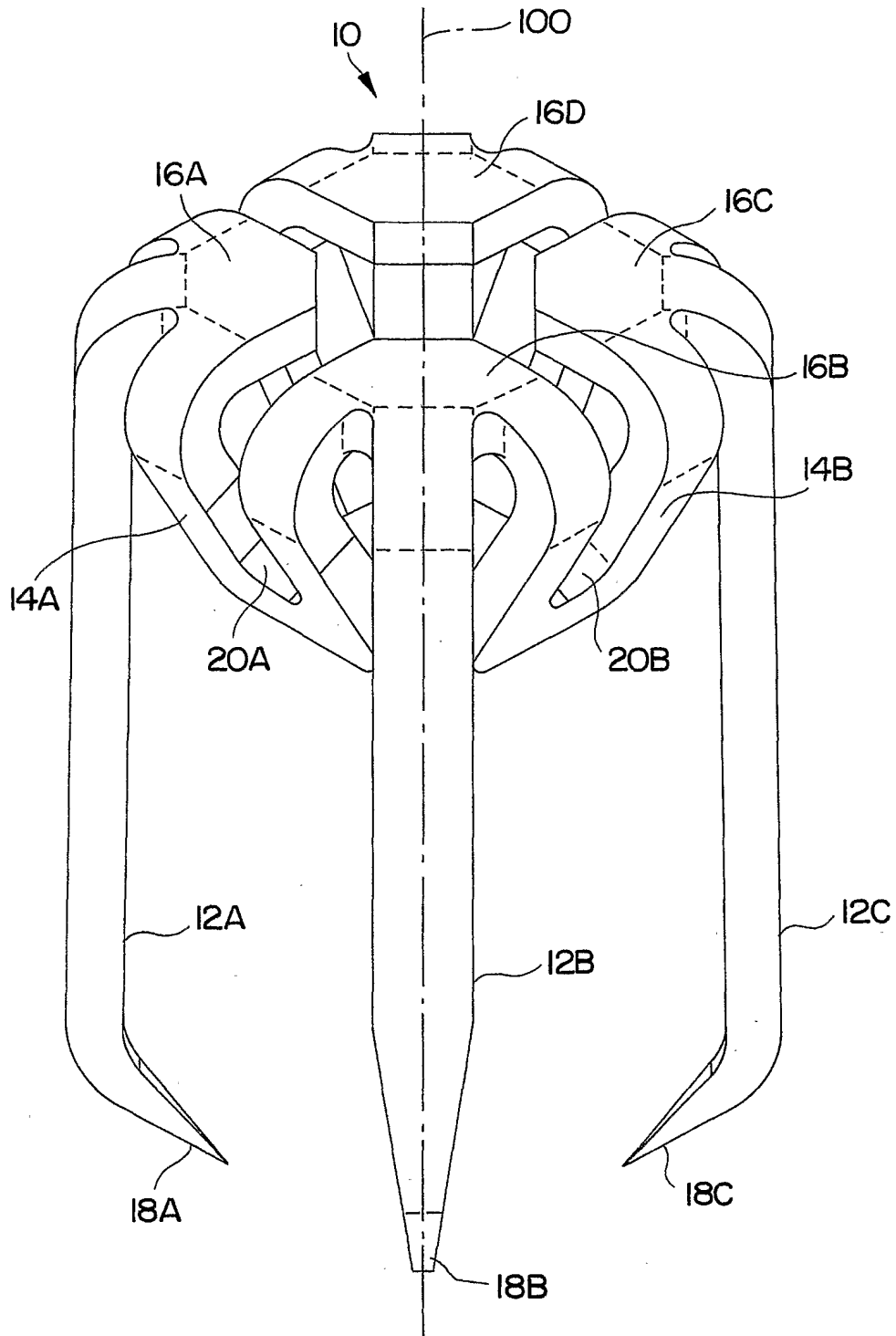

FIG. 1

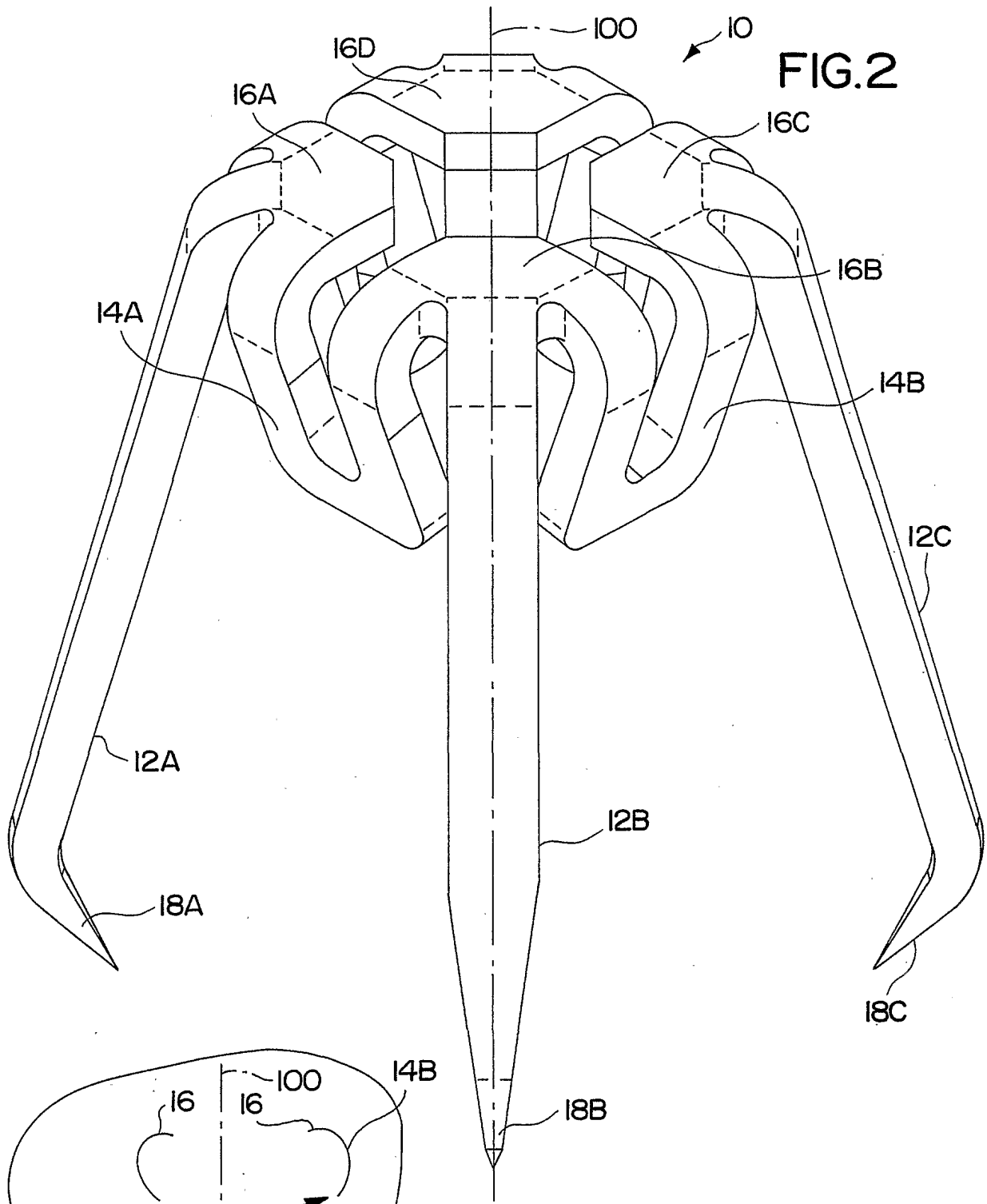

FIG. 2

FIG. 2A

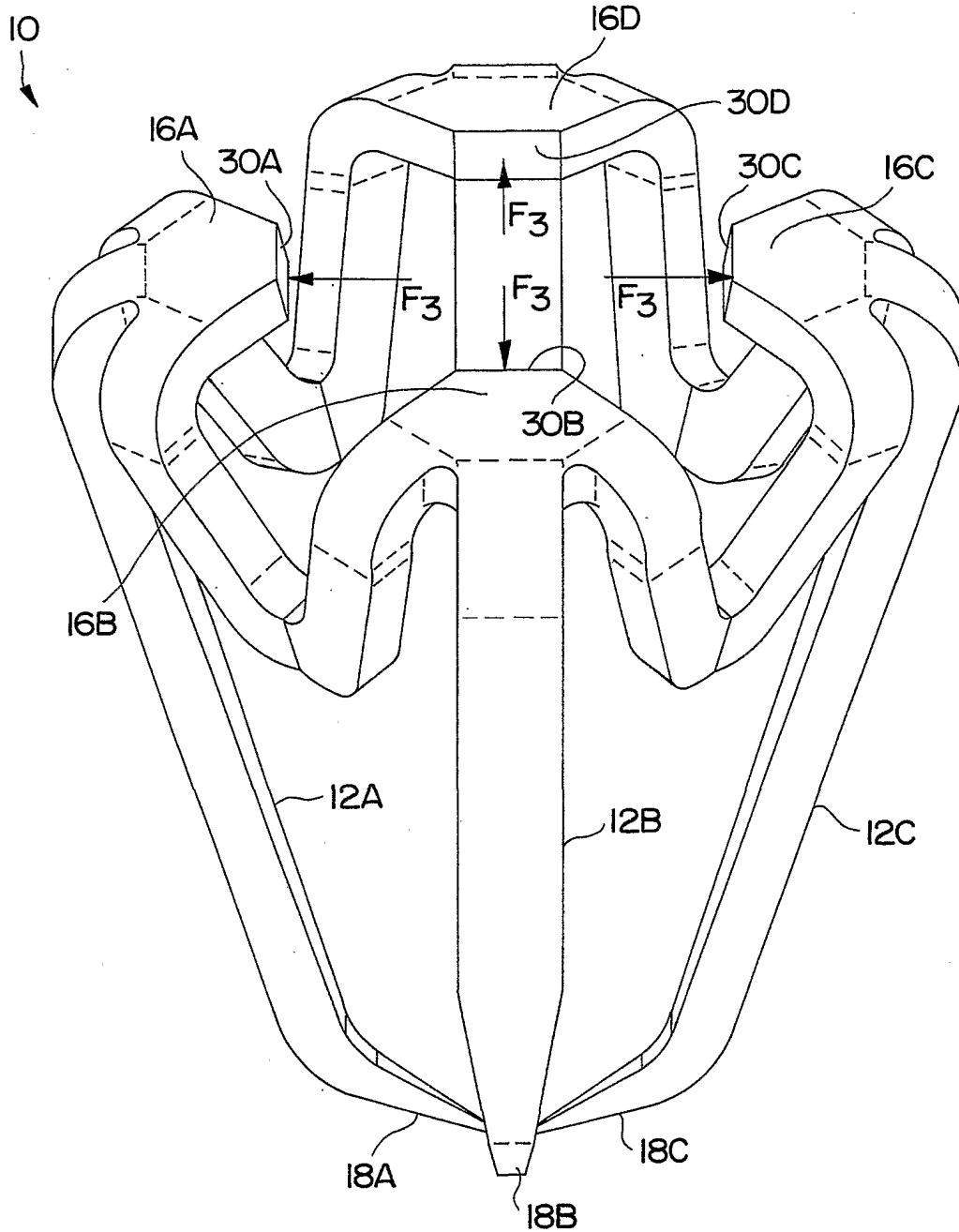

FIG. 3

4/24

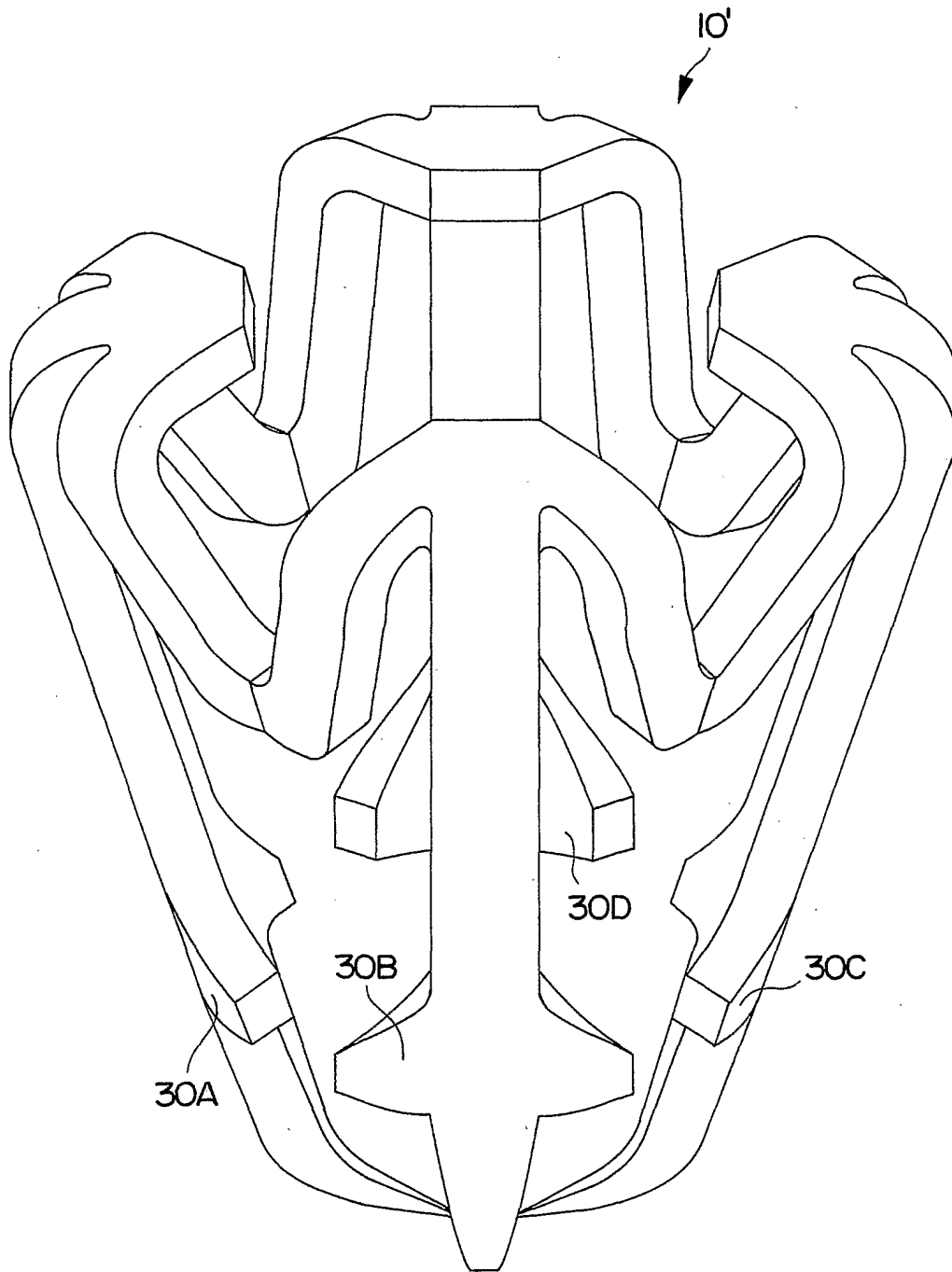

FIG.3A

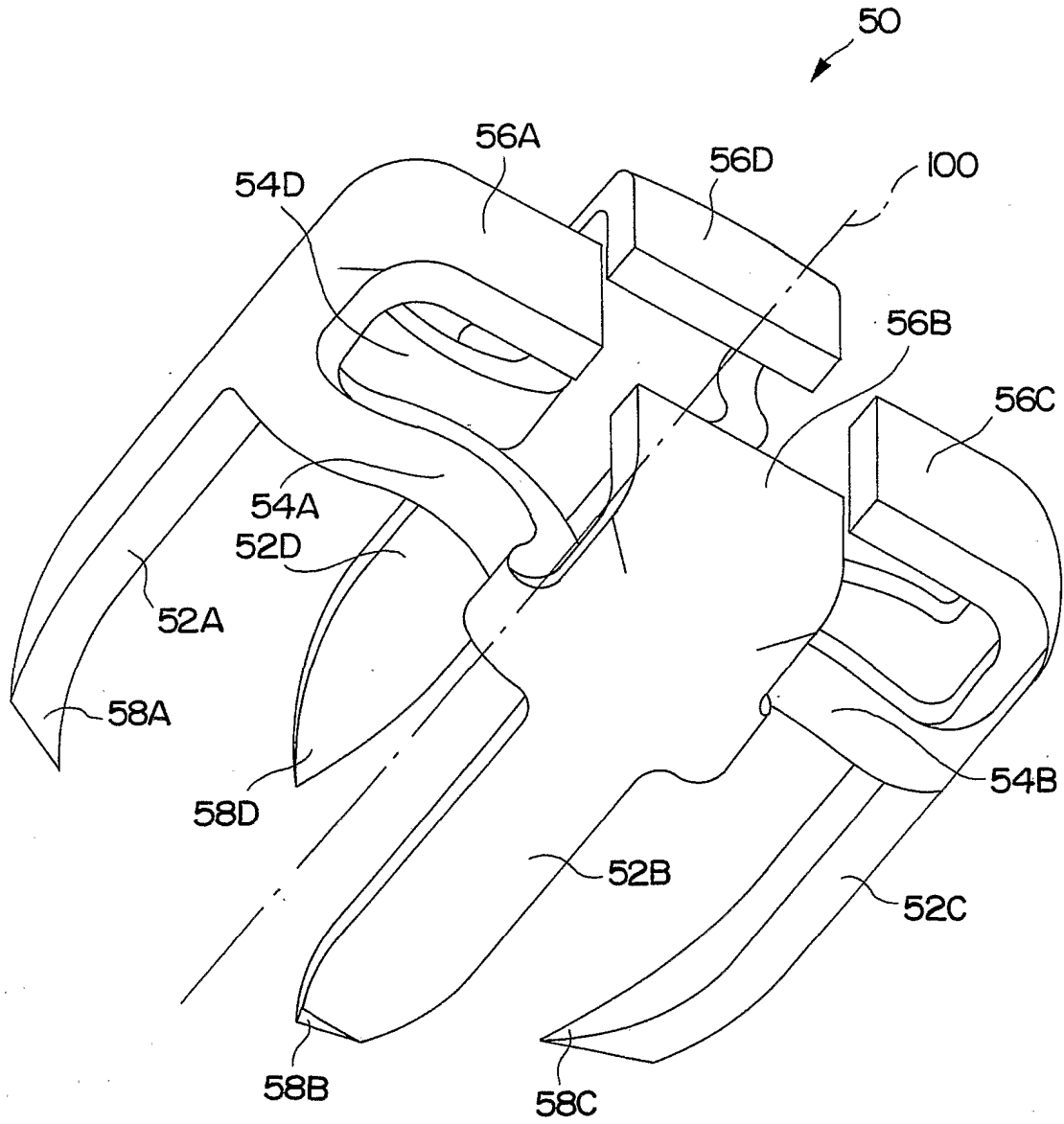

FIG.4



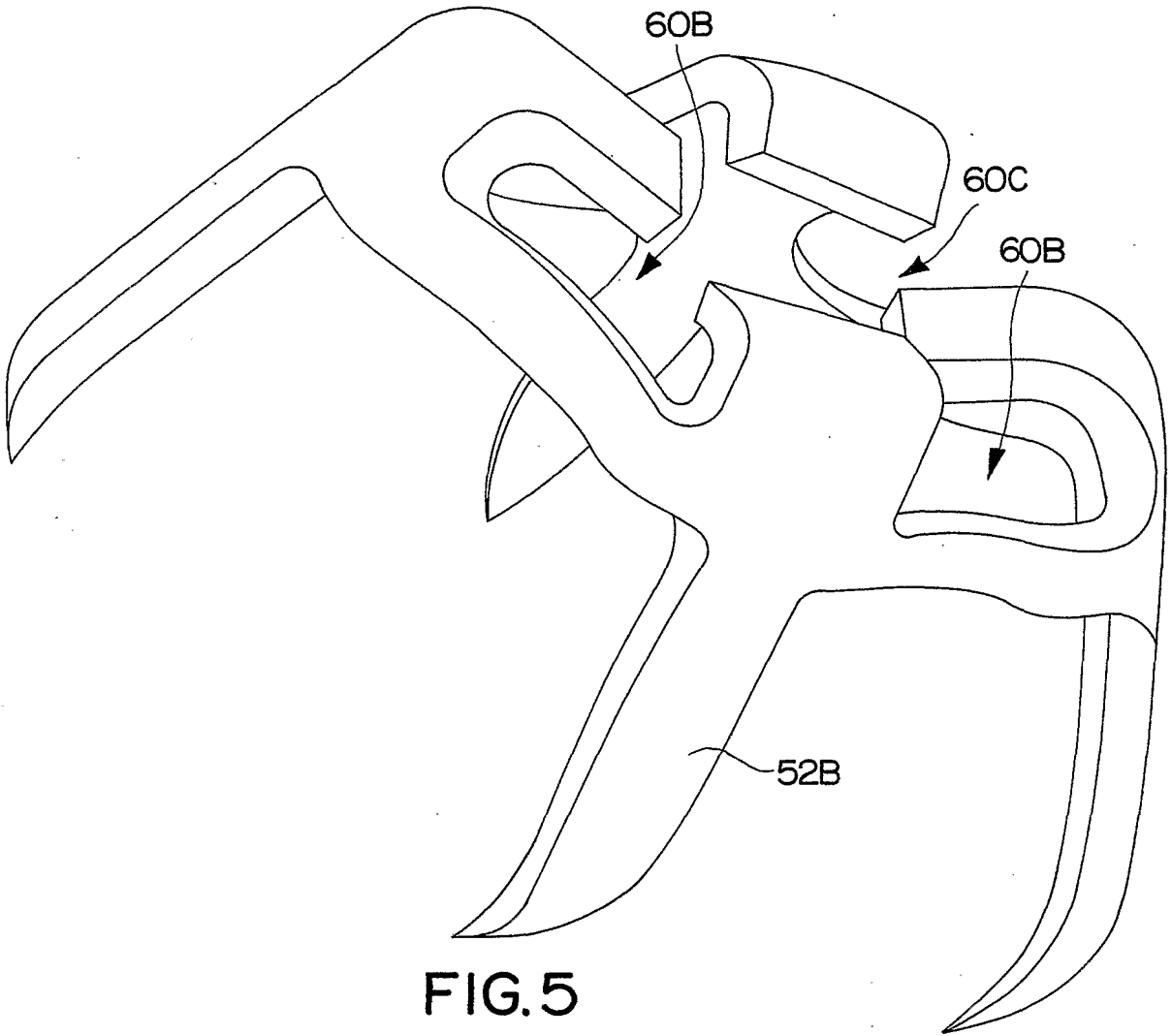

FIG. 5

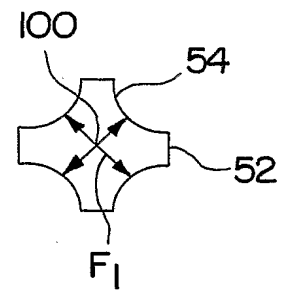

FIG. 5A

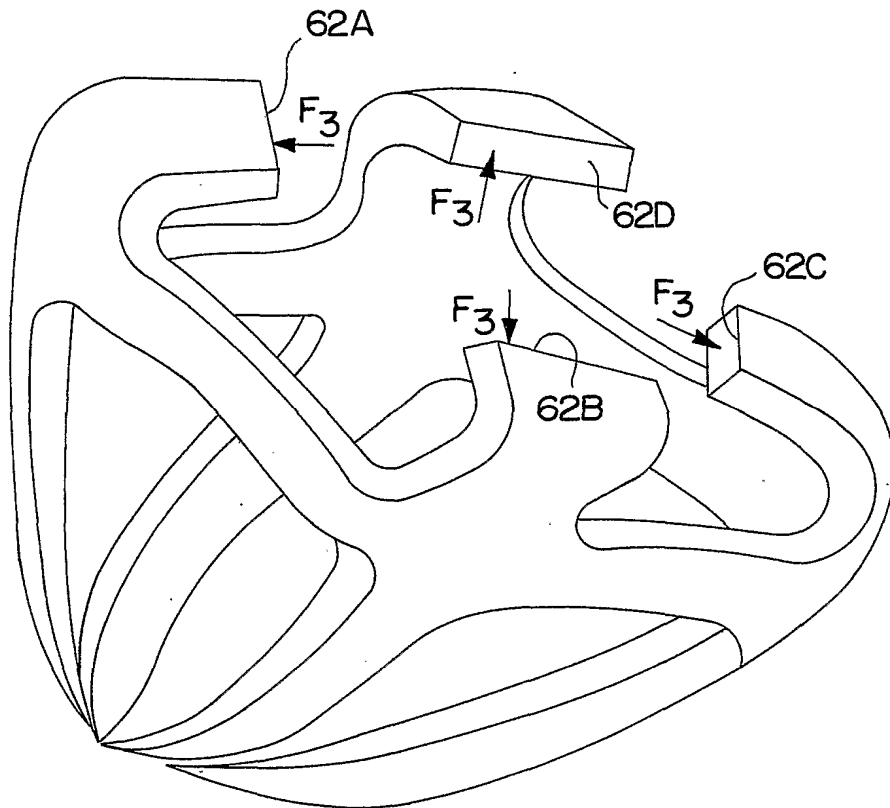
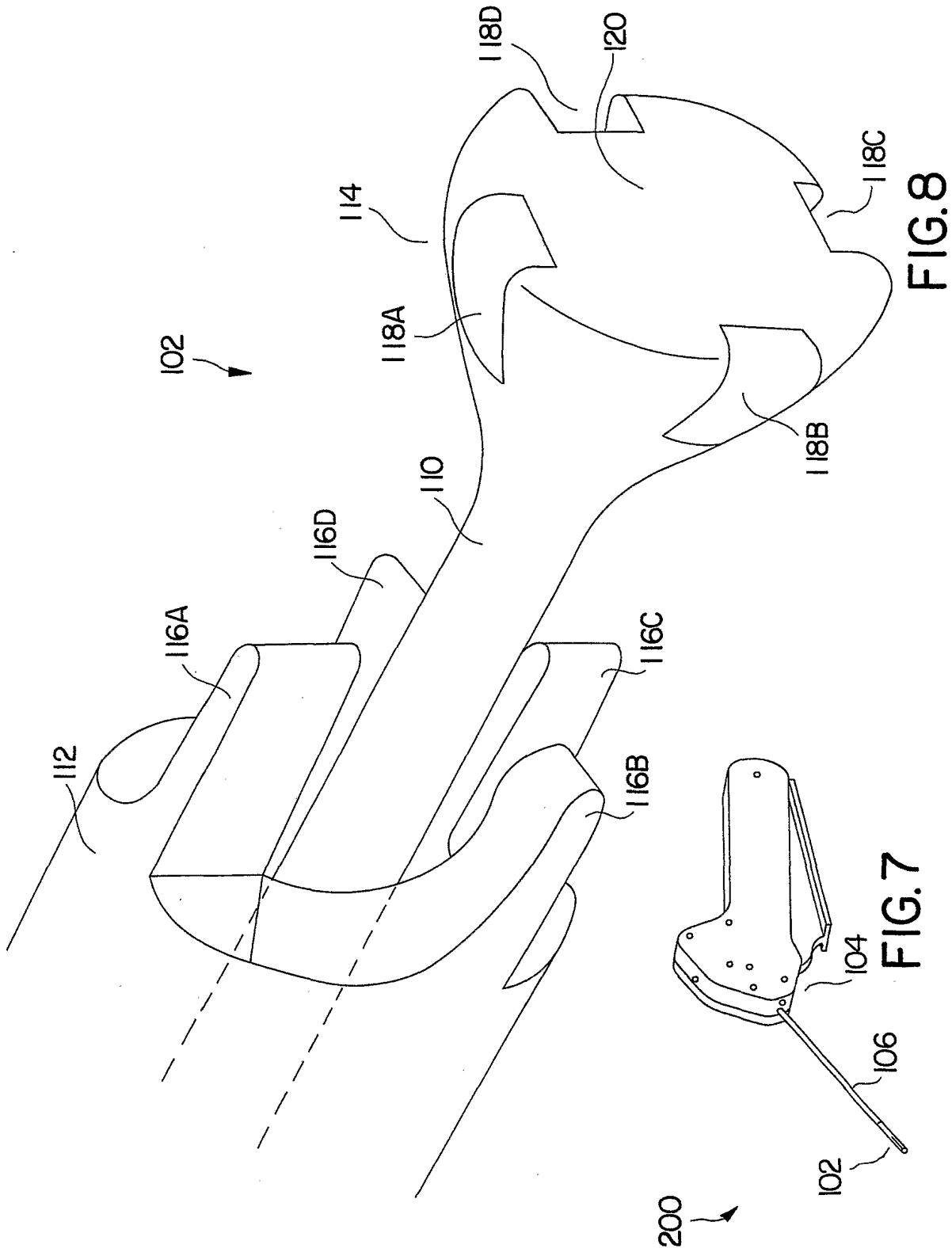

FIG.6



9/24

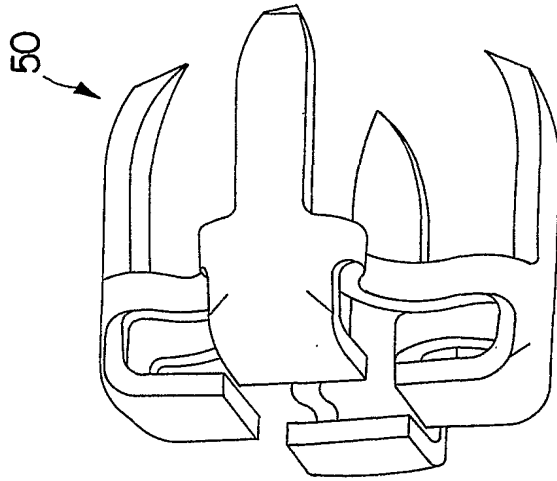

FIG. 9B

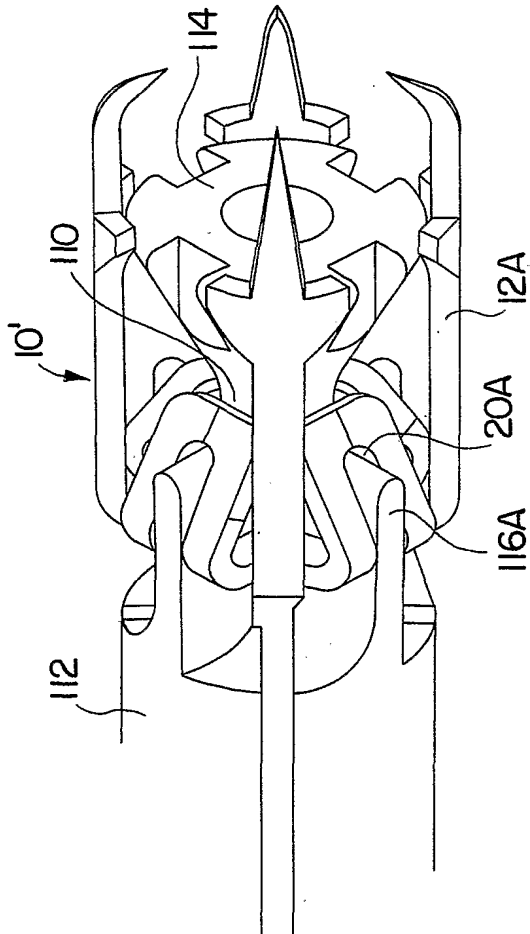

FIG. 9A

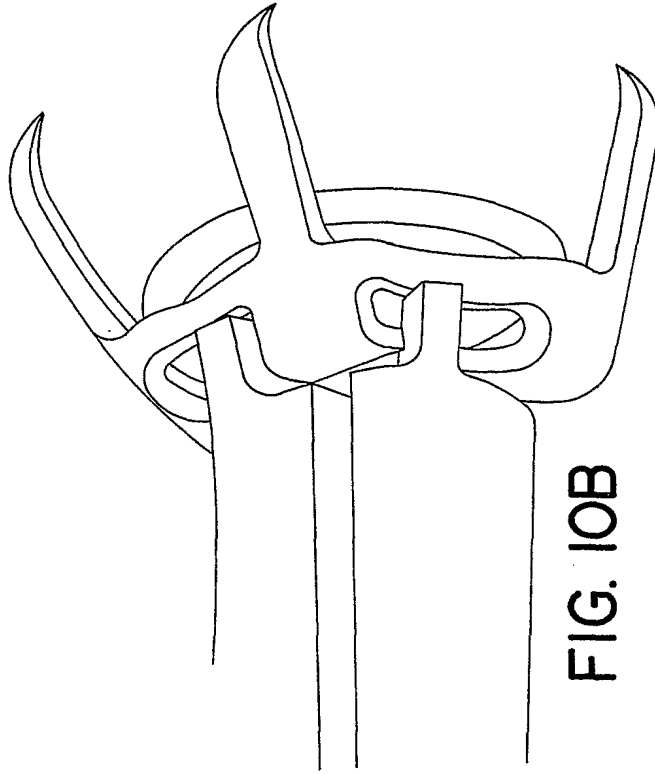

FIG. 10B

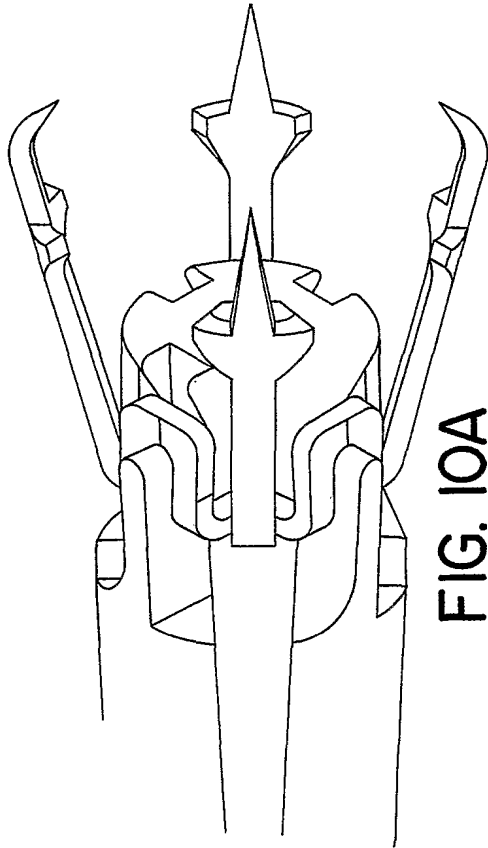

FIG. 10A

11 / 24

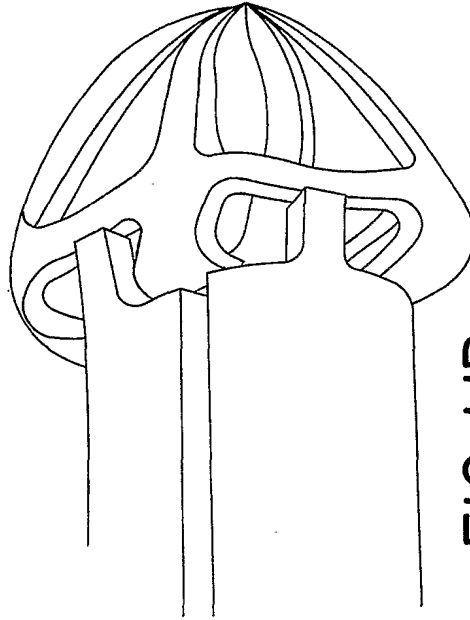

FIG. 1IB

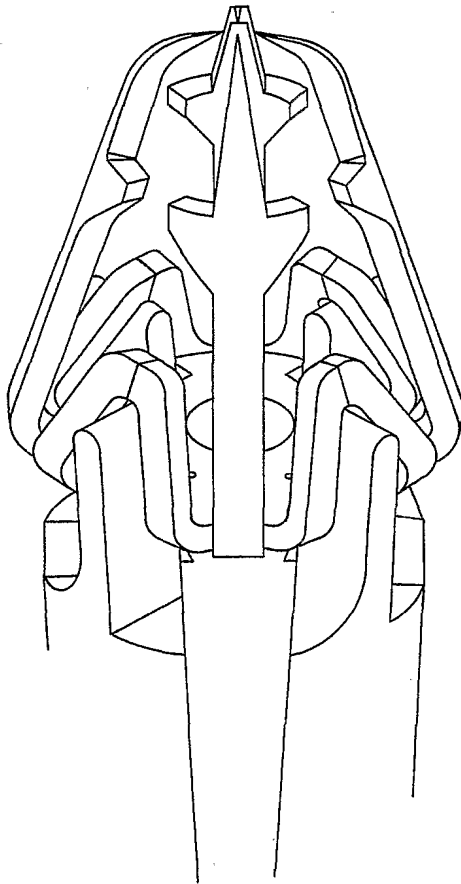

FIG. 1IA

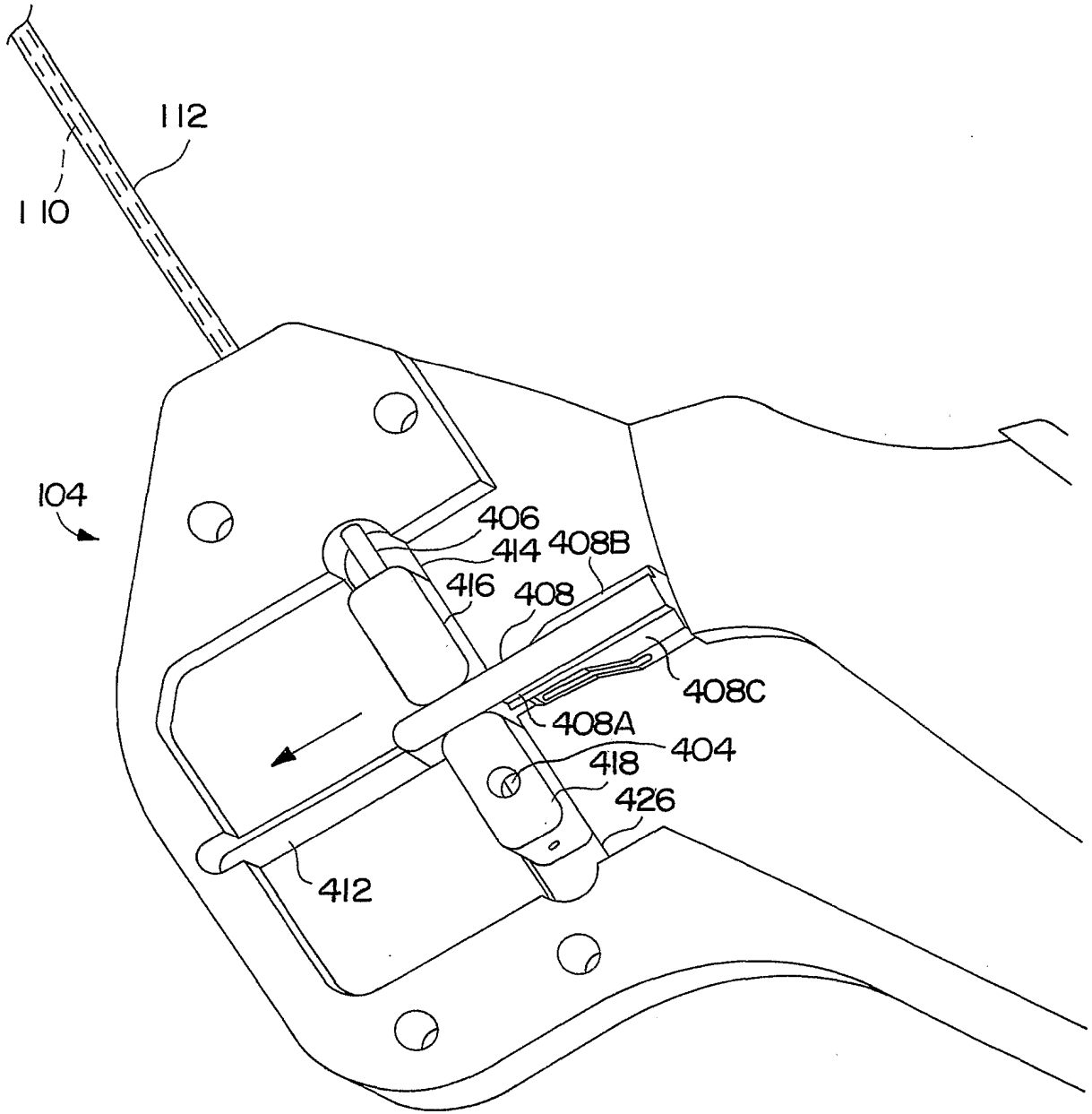

FIG. 12

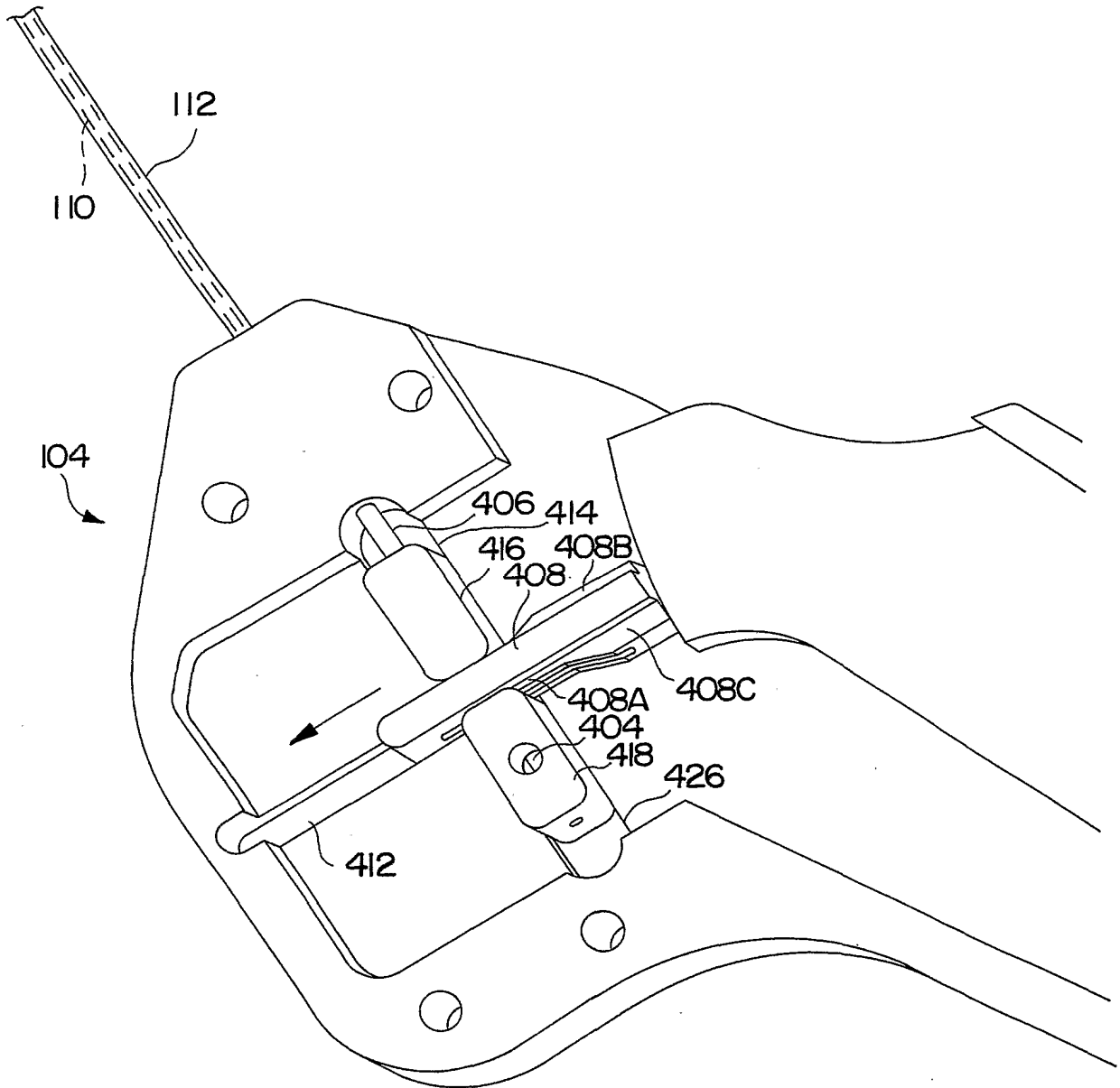

FIG. 13



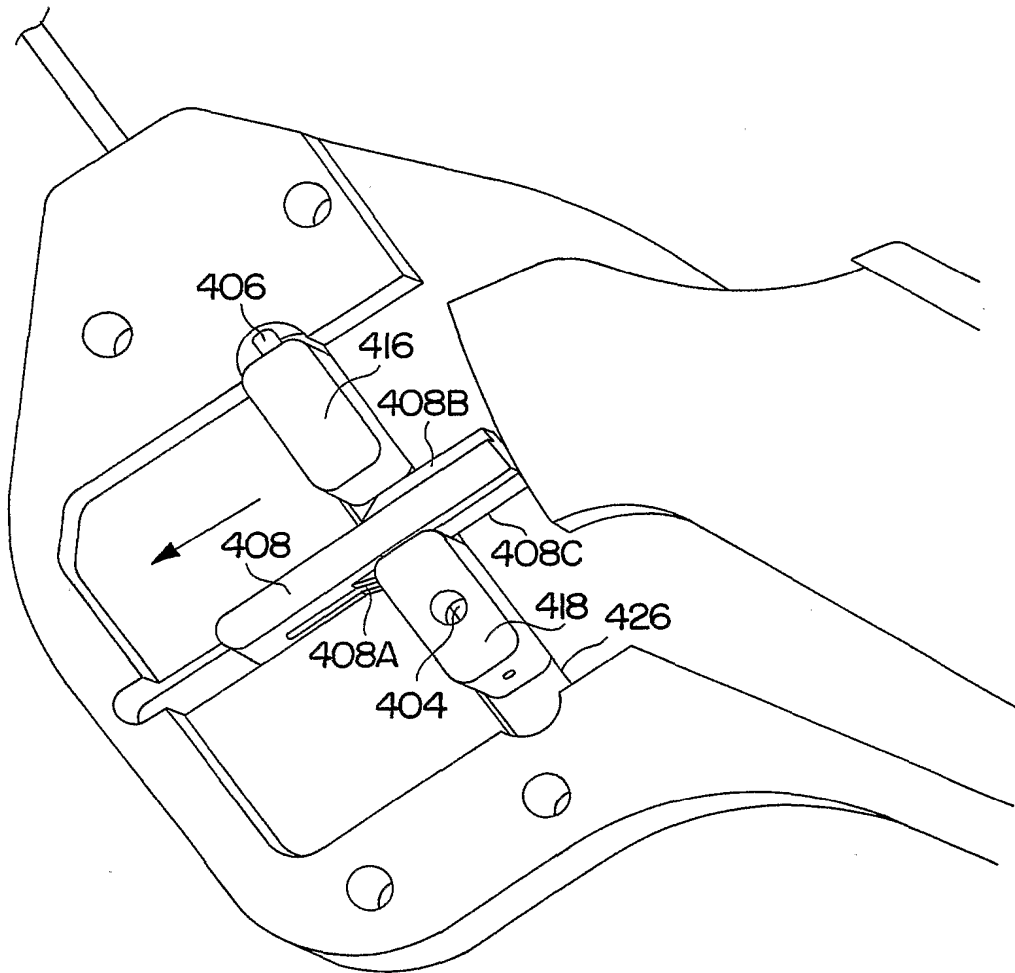

FIG. 14

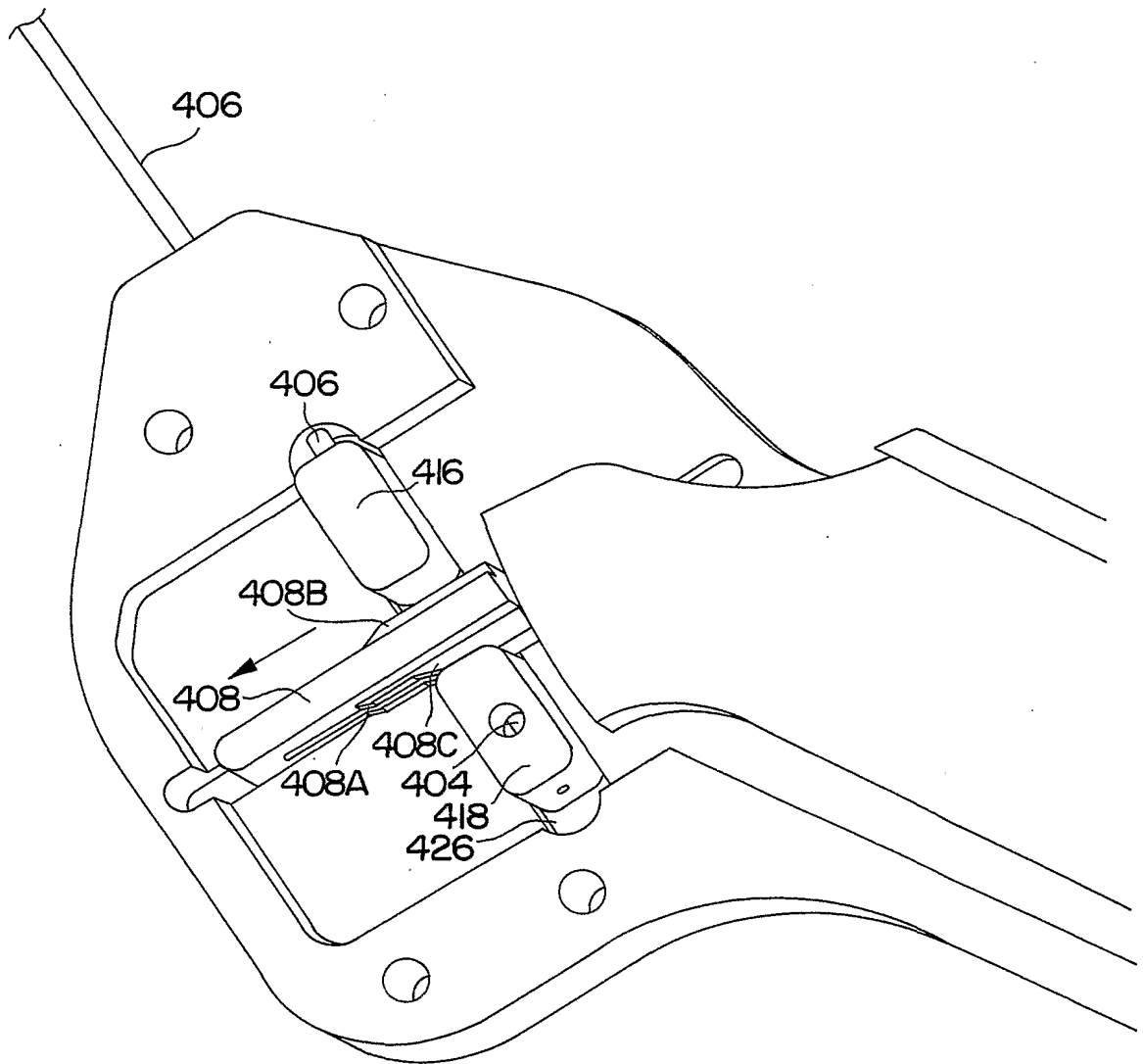

FIG.15

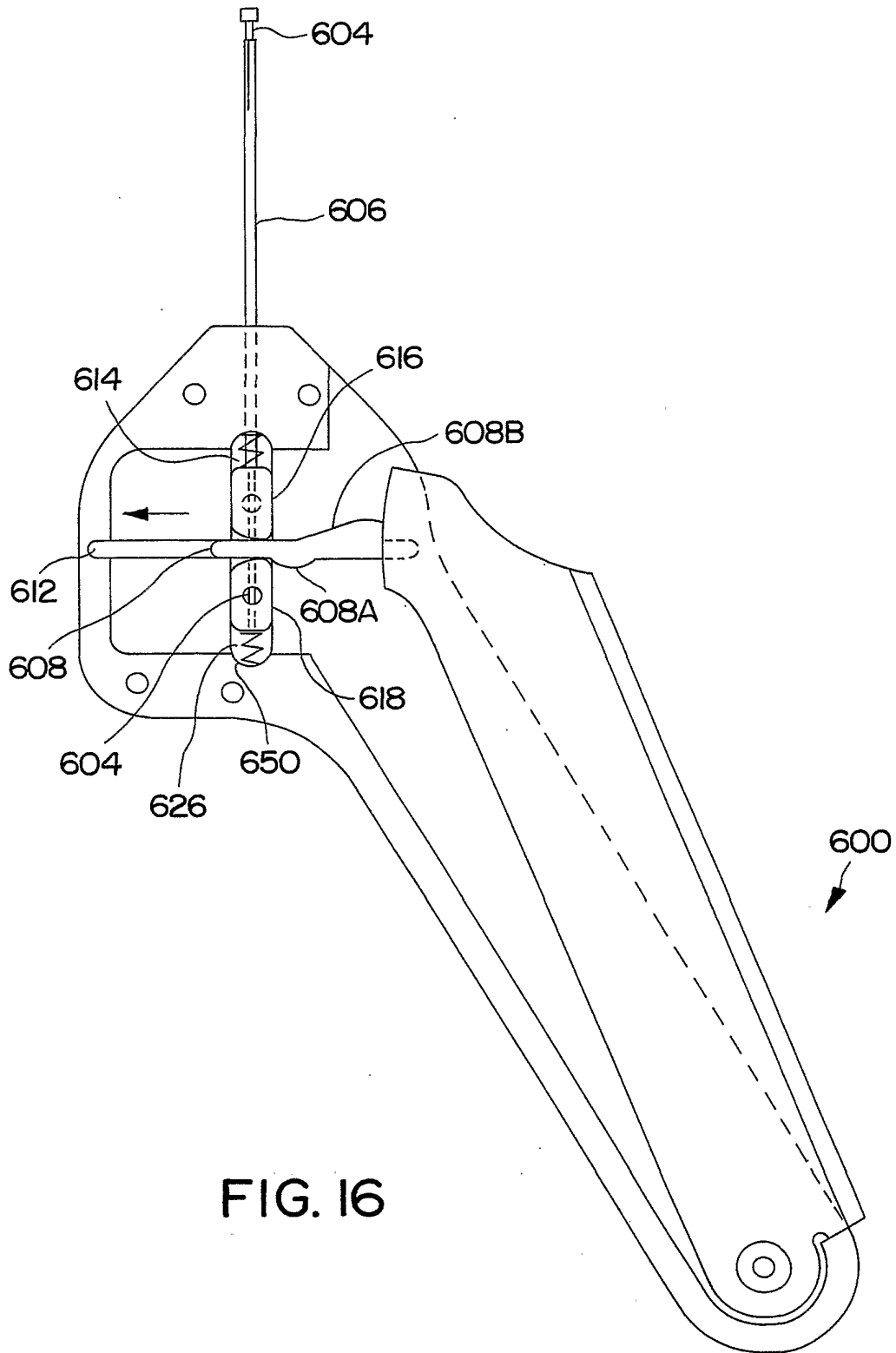

FIG. 16

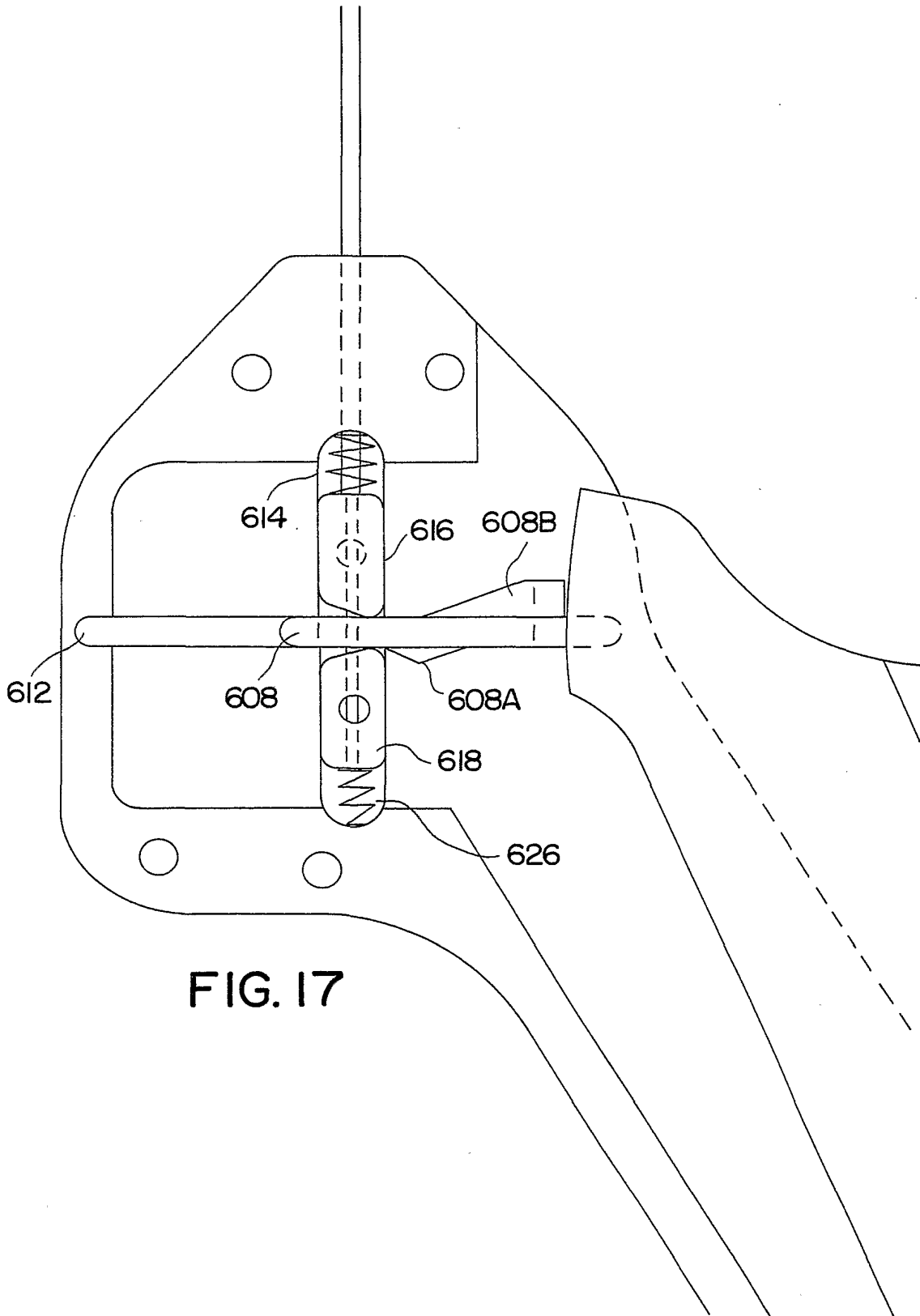

FIG. 17

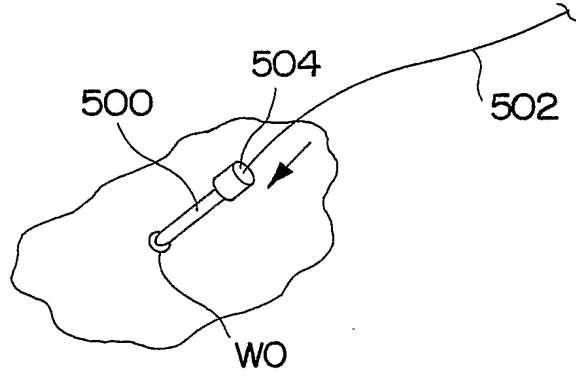

FIG. 18

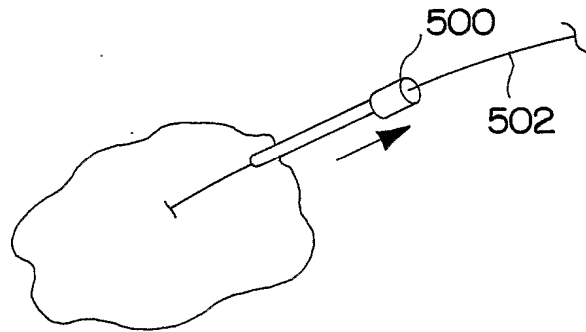

FIG. 19

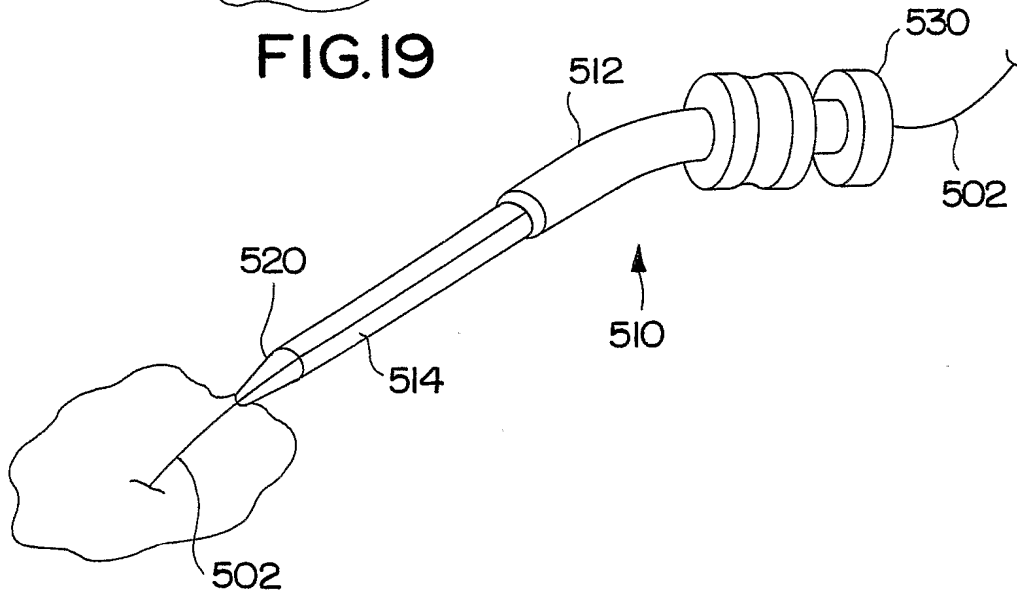

FIG. 20

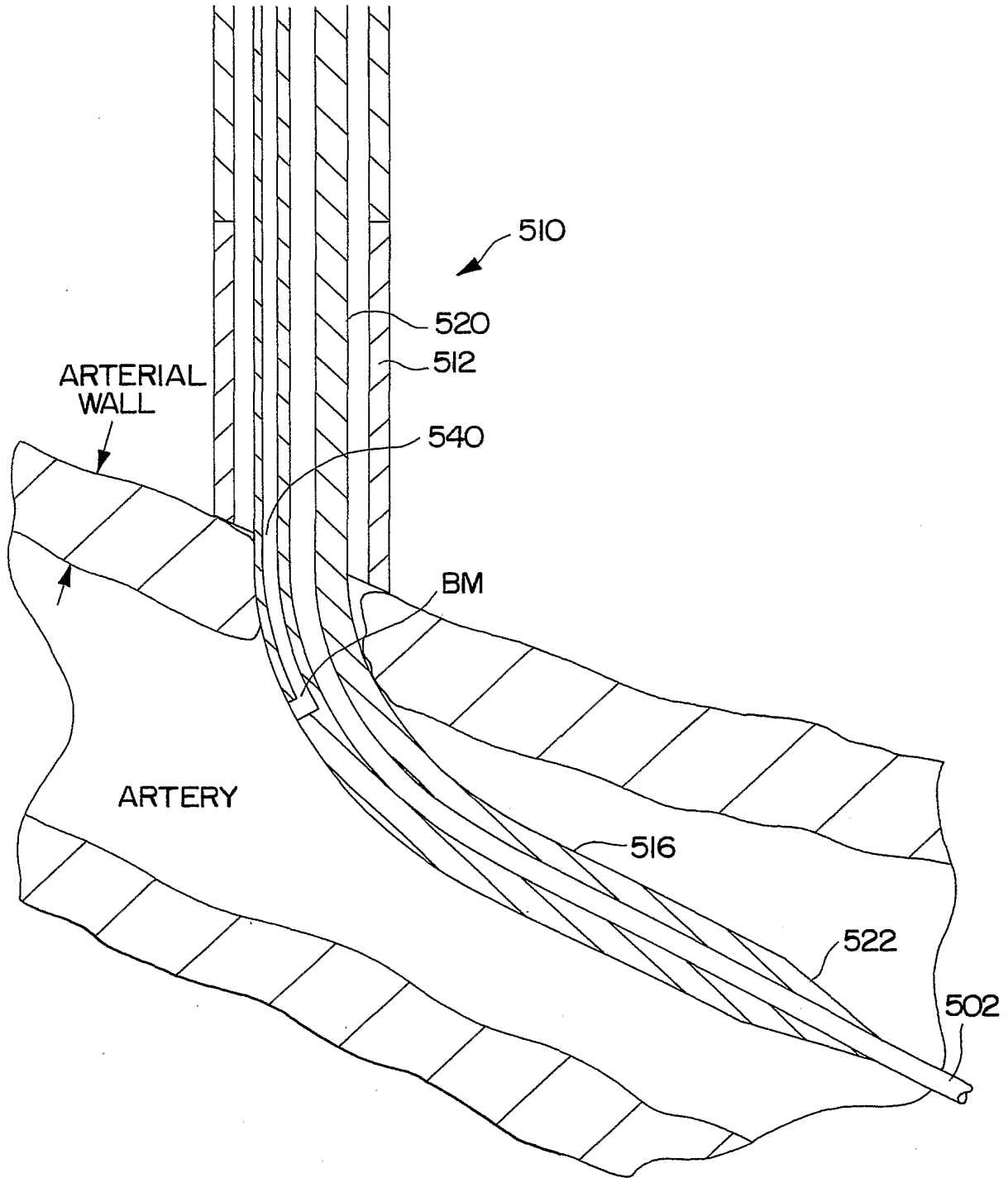

FIG. 20A

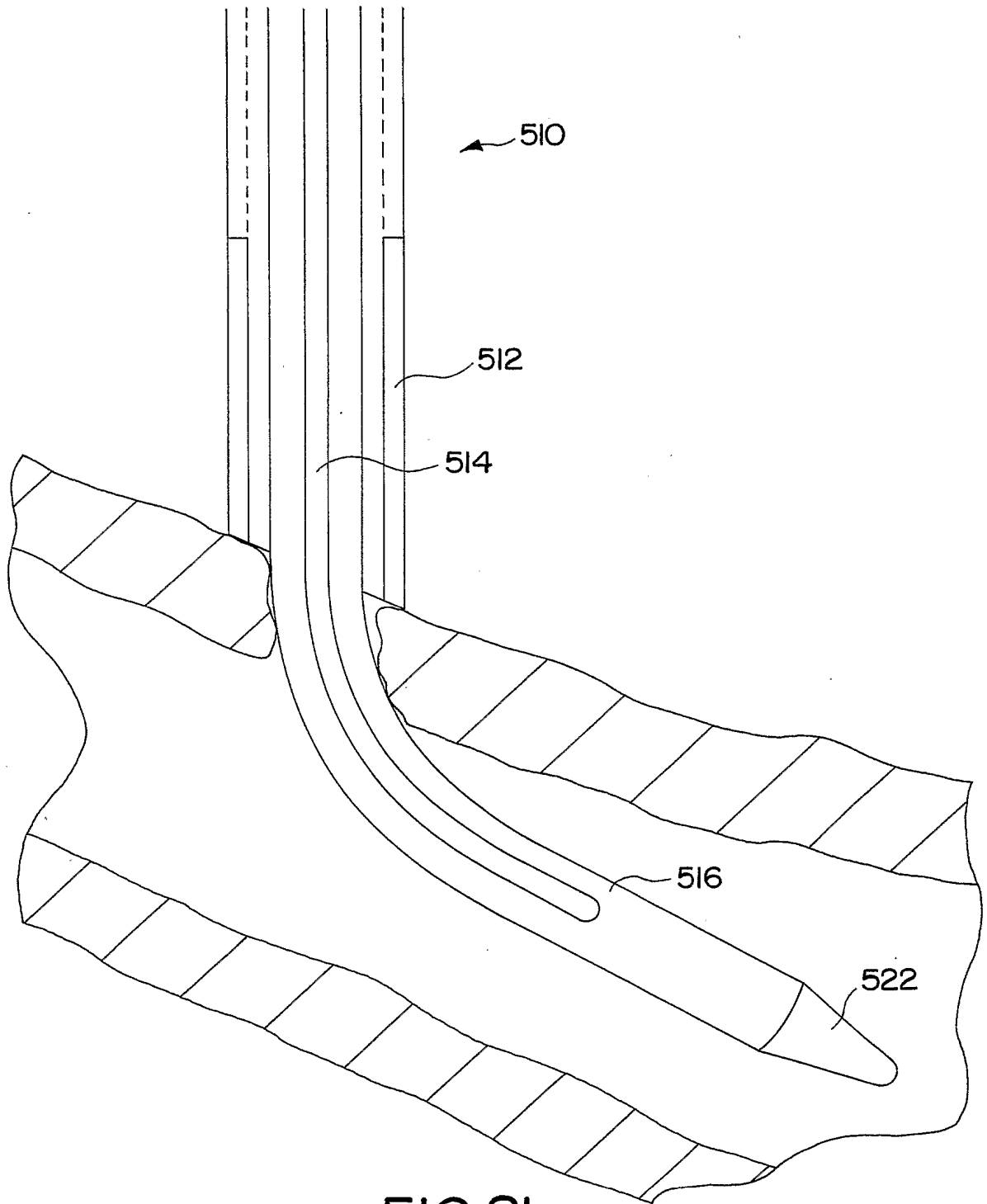
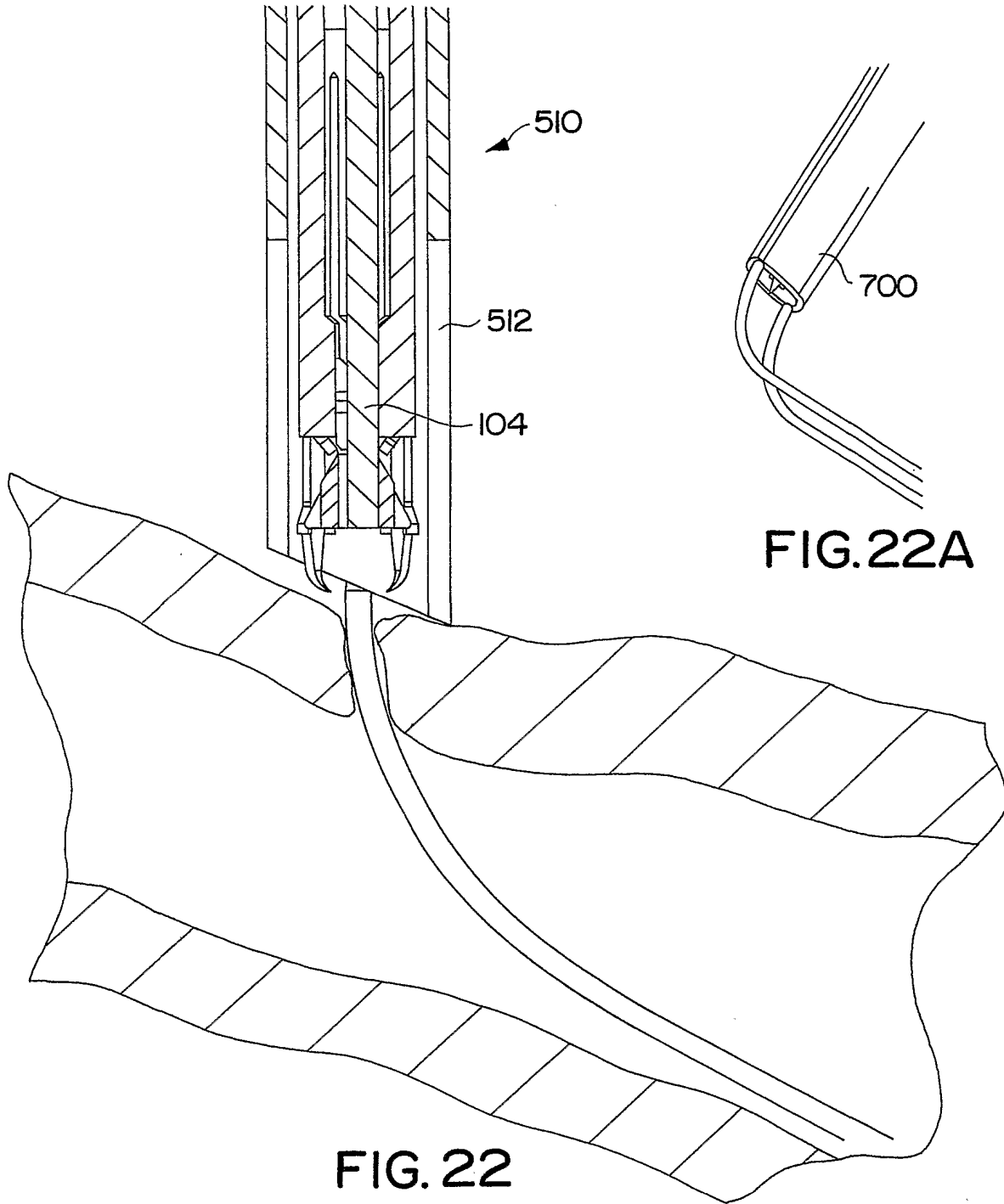

FIG. 21





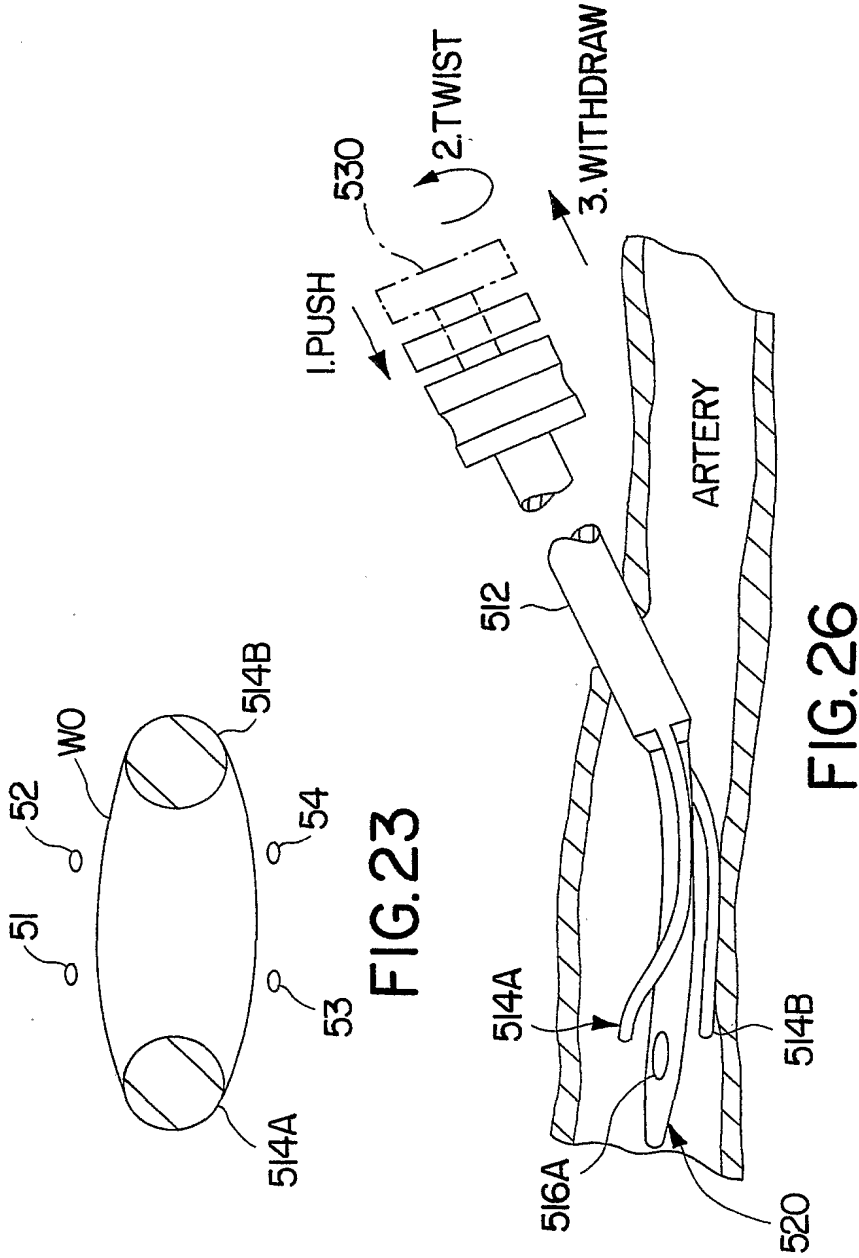

FIG. 23

FIG. 26

23/24

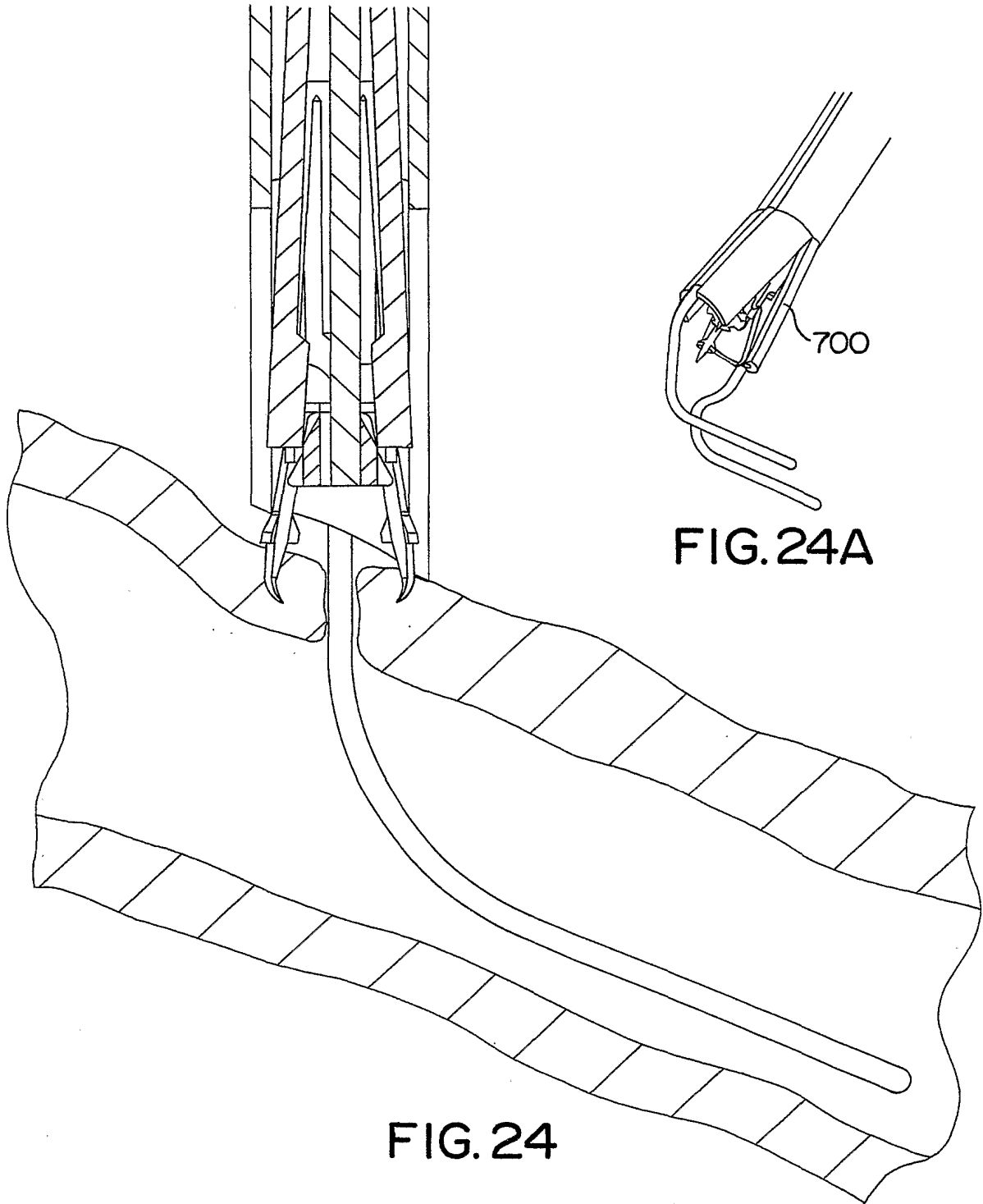
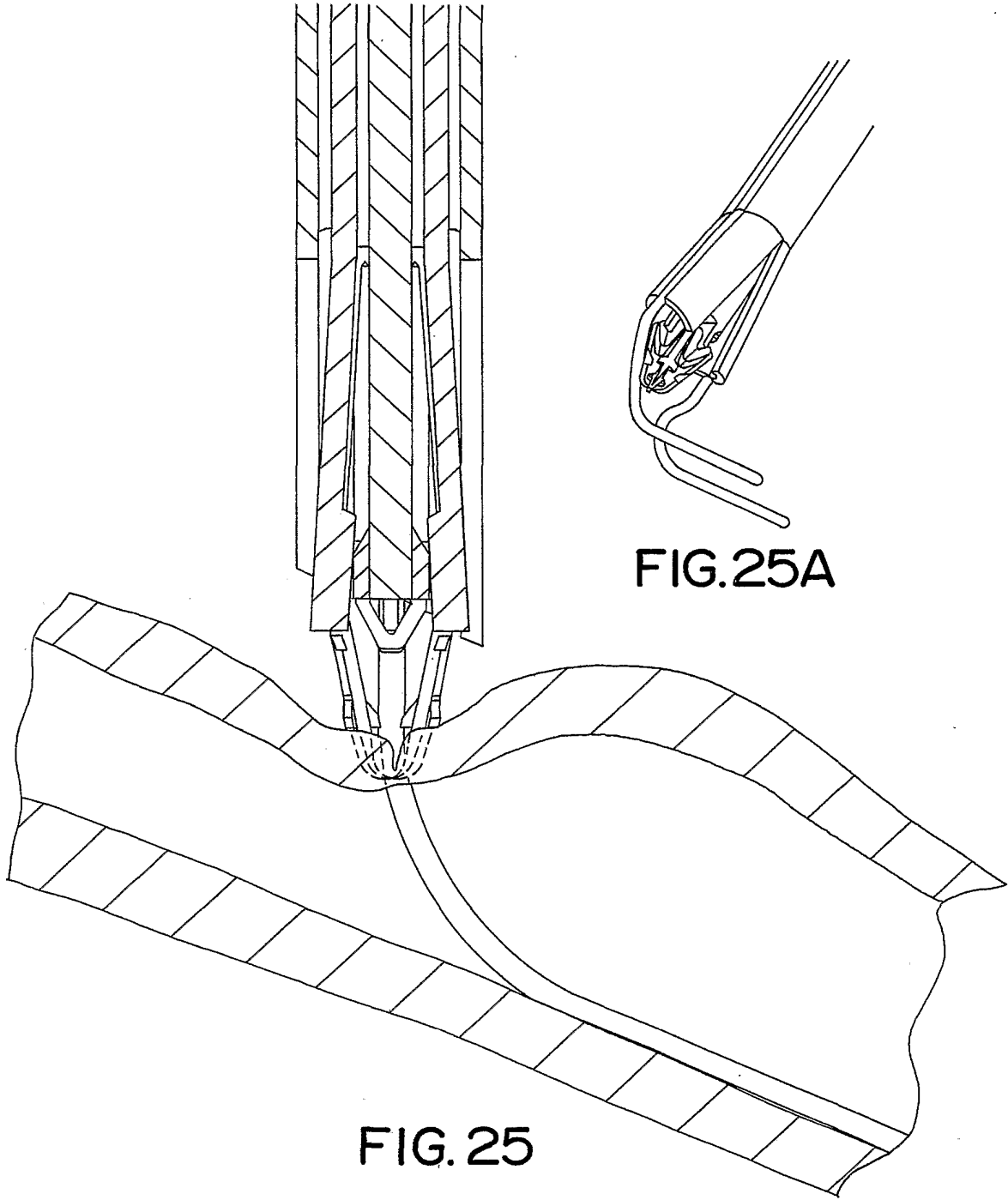

FIG. 24A

FIG. 24

24/24



# INTERNATIONAL SEARCH REPORT

International application No.  
PCT/US00/24841

**A. CLASSIFICATION OF SUBJECT MATTER**  
 IPC(7) : A61B 17/08; F16B 15/00  
 US CL : 606/219; 411/458, 460  
 According to International Patent Classification (IPC) or to both national classification and IPC

**B. FIELDS SEARCHED**  
 Minimum documentation searched (classification system followed by classification symbols)  
 U.S. : 606/219; 411/458, 460

Documentation searched other than minimum documentation to the extent that such documents are included in the fields searched

Electronic data base consulted during the international search (name of data base and, where practicable, search terms used)  
 USPTO EAST data base

**C. DOCUMENTS CONSIDERED TO BE RELEVANT**

Category*	Citation of document, with indication, where appropriate, of the relevant passages	Relevant to claim No.
X	US 5,478,354 A (TOVEY et al.) 26 December 1995, col. 5, lines 33-40 and 60-67.	1-2 and 6-9
A	US 5,122,156 A (GRANGER et al.) 16 June 1992, col. 5, lines 66-68 and col. 6, lines 1-36.	1-26
A	US 5,234,447 (KASTER et al.) 10 August 1993, see Abstract of the Disclosure.	1-26
A	US 264,290 A (HOGAN) 12 September 1882, see entire document.	1-26

Further documents are listed in the continuation of Box C.       See patent family annex.

<p>* Special categories of cited documents:</p> <p>"A" document defining the general state of the art which is not considered to be of particular relevance</p> <p>"E" earlier document published on or after the international filing date</p> <p>"L" document which may throw doubts on priority claim(s) or which is cited to establish the publication date of another citation or other special reason (as specified)</p> <p>"O" document referring to an oral disclosure, use, exhibition or other means</p> <p>"P" document published prior to the international filing date but later than the priority date claimed</p>	<p>"T" later document published after the international filing date or priority date and not in conflict with the application but cited to understand the principle or theory underlying the invention</p> <p>"X" document of particular relevance; the claimed invention cannot be considered novel or cannot be considered to involve an inventive step when the document is taken alone</p> <p>"Y" document of particular relevance; the claimed invention cannot be considered to involve an inventive step when the document is combined with one or more other such documents, such combination being obvious to a person skilled in the art</p> <p>"&amp;" document member of the same patent family</p>
--	---

Date of the actual completion of the international search  29 JANUARY 2001	Date of mailing of the international search report  <b>21 MAR 2001</b>
--	--

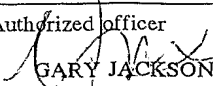
Name and mailing address of the ISA/US Commissioner of Patents and Trademarks Box PCT Washington, D.C. 20231 Facsimile No. (703) 305-3230	Authorized officer  GARY JACKSON Telephone No. (703) 308-0858
---	--

# INTERNATIONAL SEARCH REPORT

International application No.

PCT/US00/24841

## Box I Observations where certain claims were found unsearchable (Continuation of item 1 of first sheet)

This international report has not been established in respect of certain claims under Article 17(2)(a) for the following reasons:

1.  Claims Nos. :  
because they relate to subject matter not required to be searched by this Authority, namely:
  
2.  Claims Nos. :  
because they relate to parts of the international application that do not comply with the prescribed requirements to such an extent that no meaningful international search can be carried out, specifically:
  
3.  Claims Nos. :  
because they are dependent claims and are not drafted in accordance with the second and third sentences of Rule 6.4(a).

## Box II Observations where unity of invention is lacking (Continuation of item 2 of first sheet)

This International Searching Authority found multiple inventions in this international application, as follows:

Please See Extra Sheet.

1.  As all required additional search fees were timely paid by the applicant, this international search report covers all searchable claims.
2.  As all searchable claims could be searched without effort justifying an additional fee, this Authority did not invite payment of any additional fee.
3.  As only some of the required additional search fees were timely paid by the applicant, this international search report covers only those claims for which fees were paid, specifically claims Nos.:
  
4.  No required additional search fees were timely paid by the applicant. Consequently, this international search report is restricted to the invention first mentioned in the claims; it is covered by claims Nos.:

1-26

Remark on Protest

The additional search fees were accompanied by the applicant's protest.

No protest accompanied the payment of additional search fees.

## INTERNATIONAL SEARCH REPORT

International application No.  
PCT/US00/24841

### BOX II. OBSERVATIONS WHERE UNITY OF INVENTION WAS LACKING

This ISA found multiple inventions as follows:

This application contains the following inventions or groups of inventions which are not so linked as to form a single inventive concept under PCT Rule 13.1. In order for all inventions to be searched, the appropriate additional search fees must be paid.

Group I, claim(s) 1-26, drawn to a surgical staple.

Group II, claim(s) 27-34, drawn to a surgical stapler.

Group III, claims 37-48, drawn to an introducer sheath.

The inventions listed as Groups I and III do not relate to a single inventive concept under PCT Rule 13.1 because, under PCT Rule 13.2, they lack the same or corresponding special technical features for the following reasons: The staple of claim 1 does not require the particulars of the introducer sheath as recited in claims 37-38.

The inventions listed as Groups I and II do not relate to a single inventive concept under PCT Rule 13.1 because, under PCT Rule 13.2, they lack the same or corresponding special technical features for the following reasons: The staple of claim 1, does not require the particulars of the stapler to close a wound opening.

The inventions listed as Groups II and Group III do not relate to a single inventive concept under PCT Rule 13.1 because, under PCT Rule 13.2, they lack the same or corresponding special technical features for the following reasons: The introducer sheath can be used in other surgical procedure and is not required for the claimed surgical stapler.